

Crease the diagonals

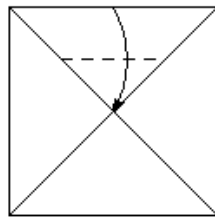

Fold the top edge to the center point, creasing only between the diagonals

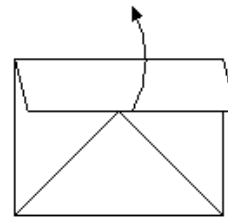

Unfold

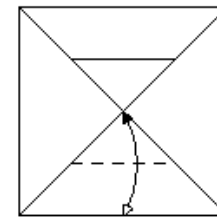

Repeat on the bottom (fold and unfold)

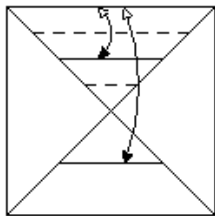

Fold and unfold on 1/4 and 3/4 marks

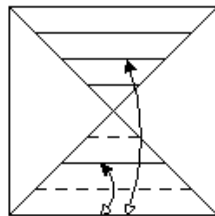

Repeat on the bottom

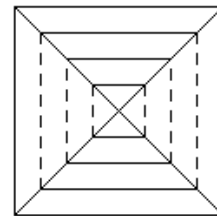

Repeat on left and right sides

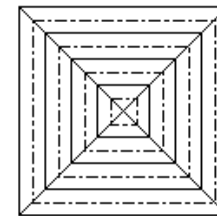

Turn over, and crease in between the squares in the opposite direction

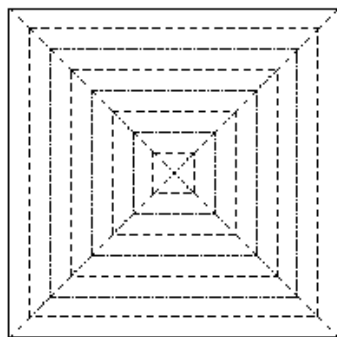

Final crease pattern

- Valley fold
- ..... Mountain fold

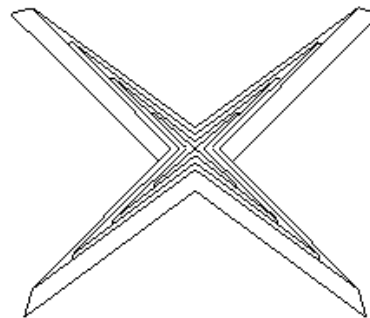

Folding the crease pattern completely forms an "X" shape

Partially opening it forms a hyper

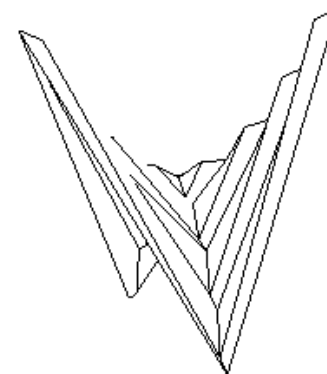

Demaine,  
Demaine,  
Lubiw  
1999

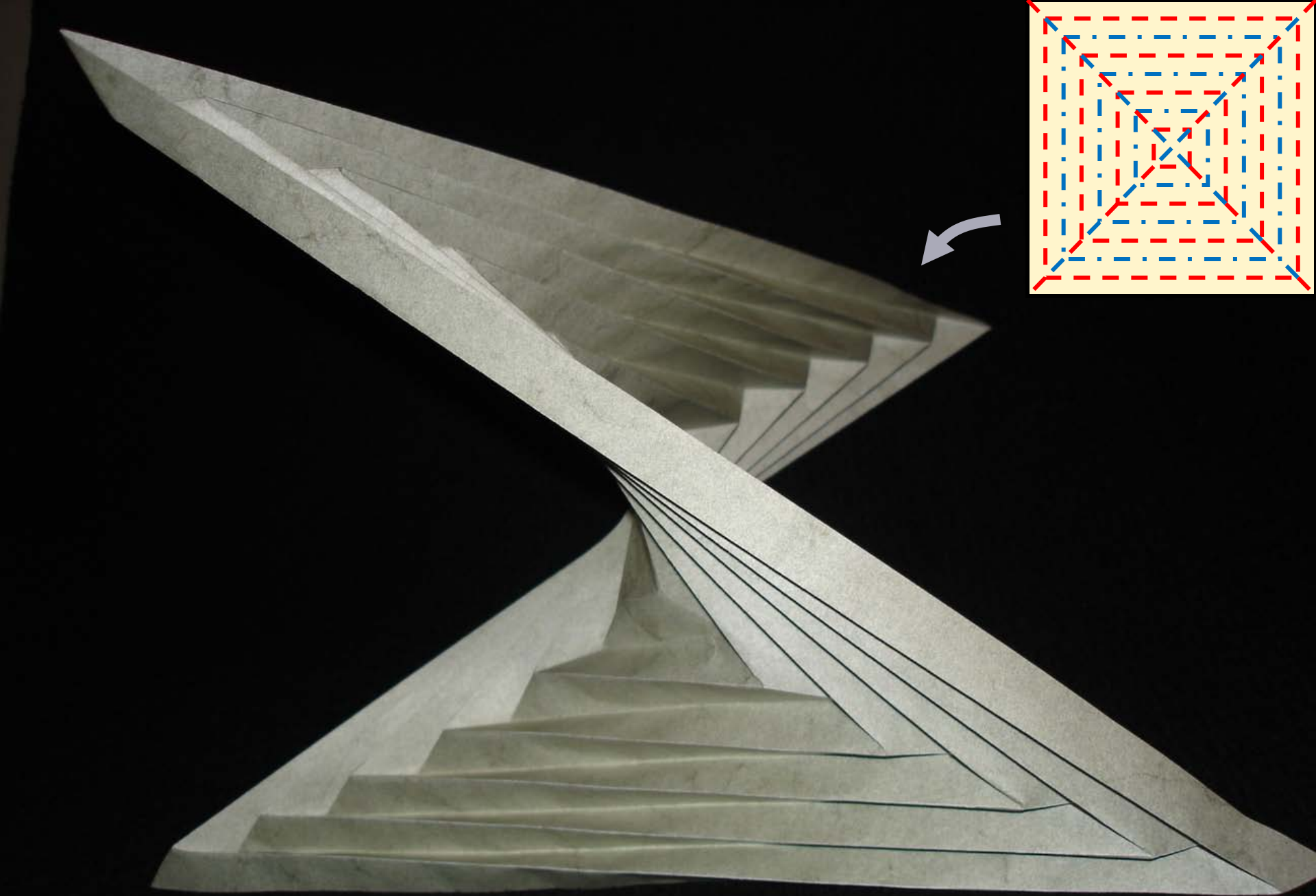

Courtesy of Jenna Fizel. Used with permission.

[Albers at Bauhaus, 1927-1928]<sub>2</sub>

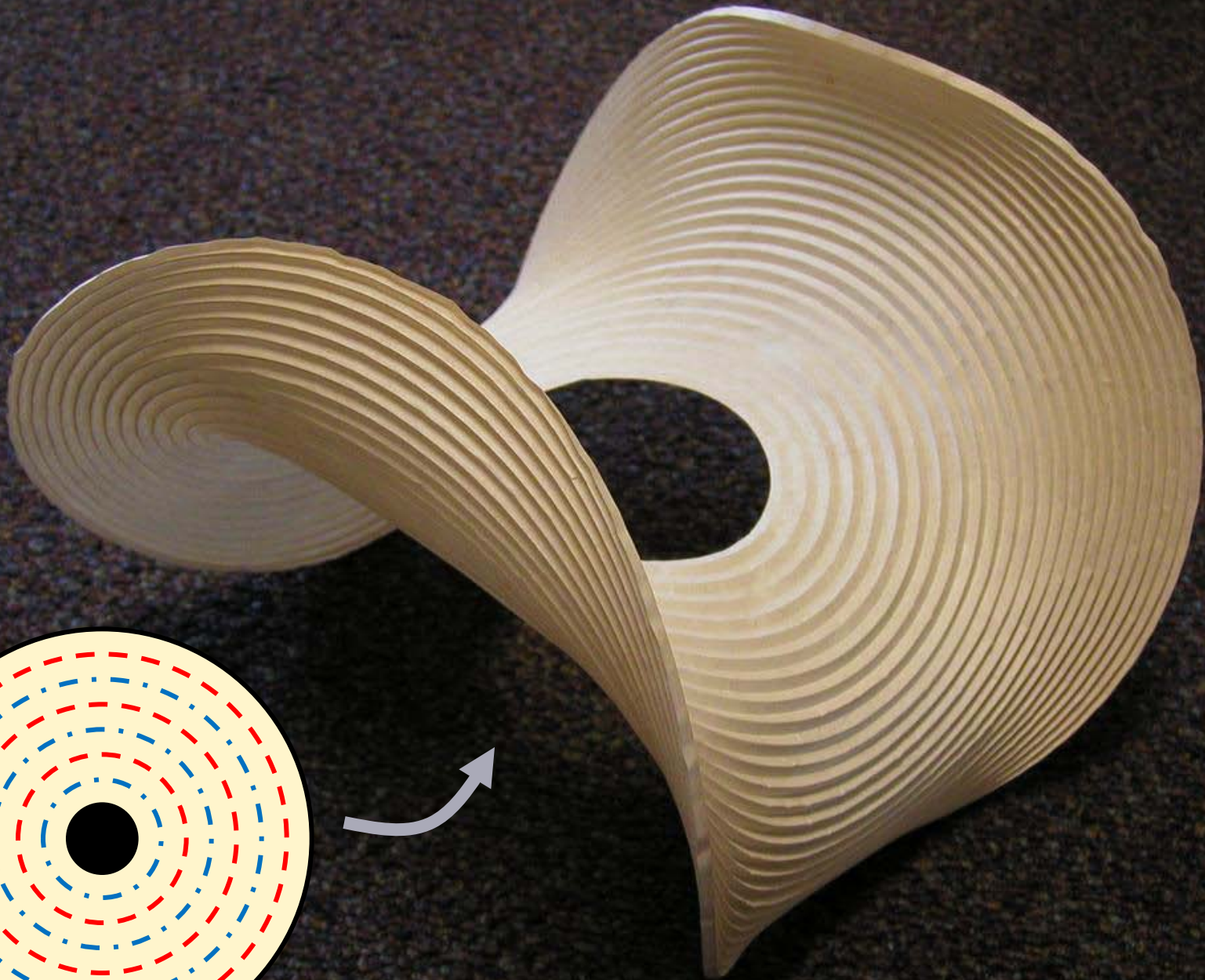
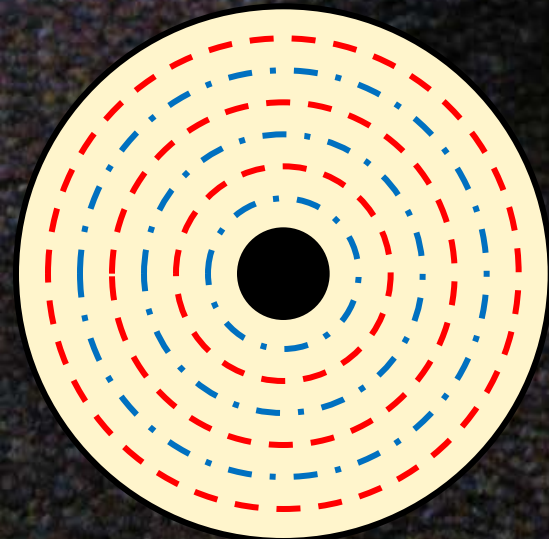

[Albers at Bauhaus, 1927-1928]

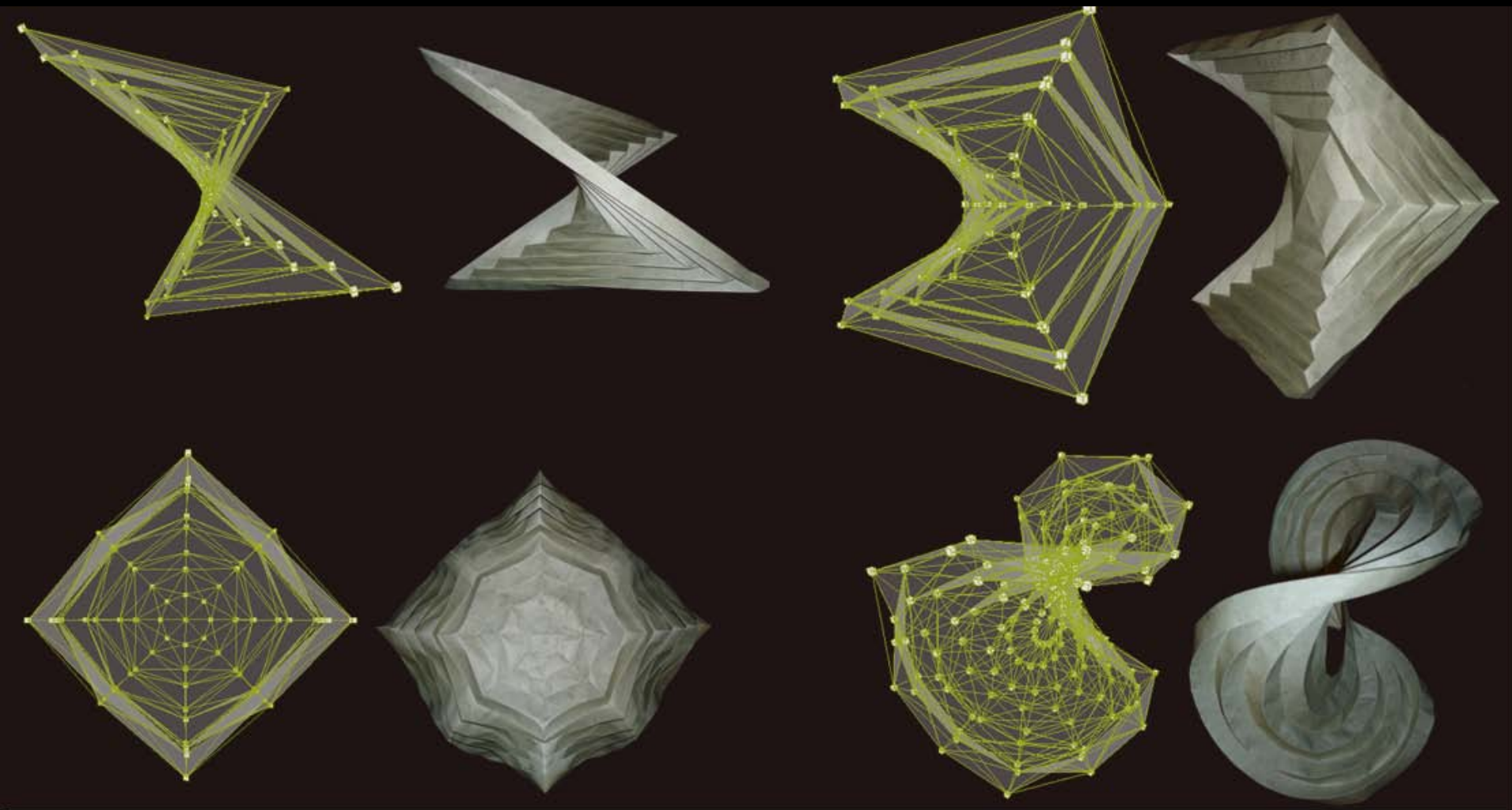

Courtesy of Erik Demaine, Martin Demaine, Jenna Fizel, and John Ochsendorf. Used with permission.

# Virtual Origami

Demaine, Demaine, Fizel, Ochsendorf 2006

6 sides  
15 folds  
30 scale

piece  
solid  
free-form  
tools  
view

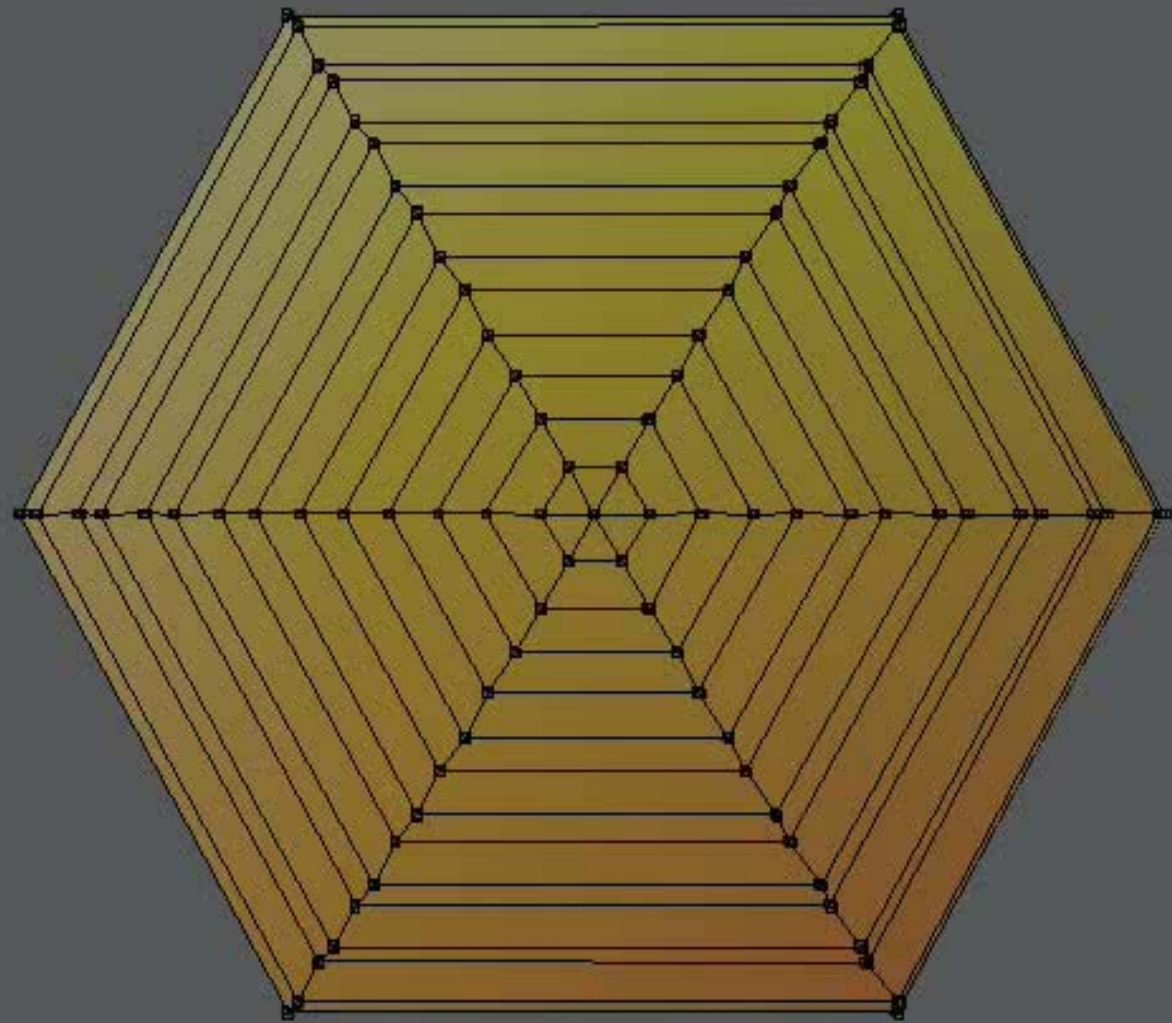

# Virtual Origami

Demaine, Demaine, Fizel, Ochsendorf 2006

Courtesy of Erik Demaine, Martin Demaine, Jenna Fizel, and John Ochsendorf. Used with permission.

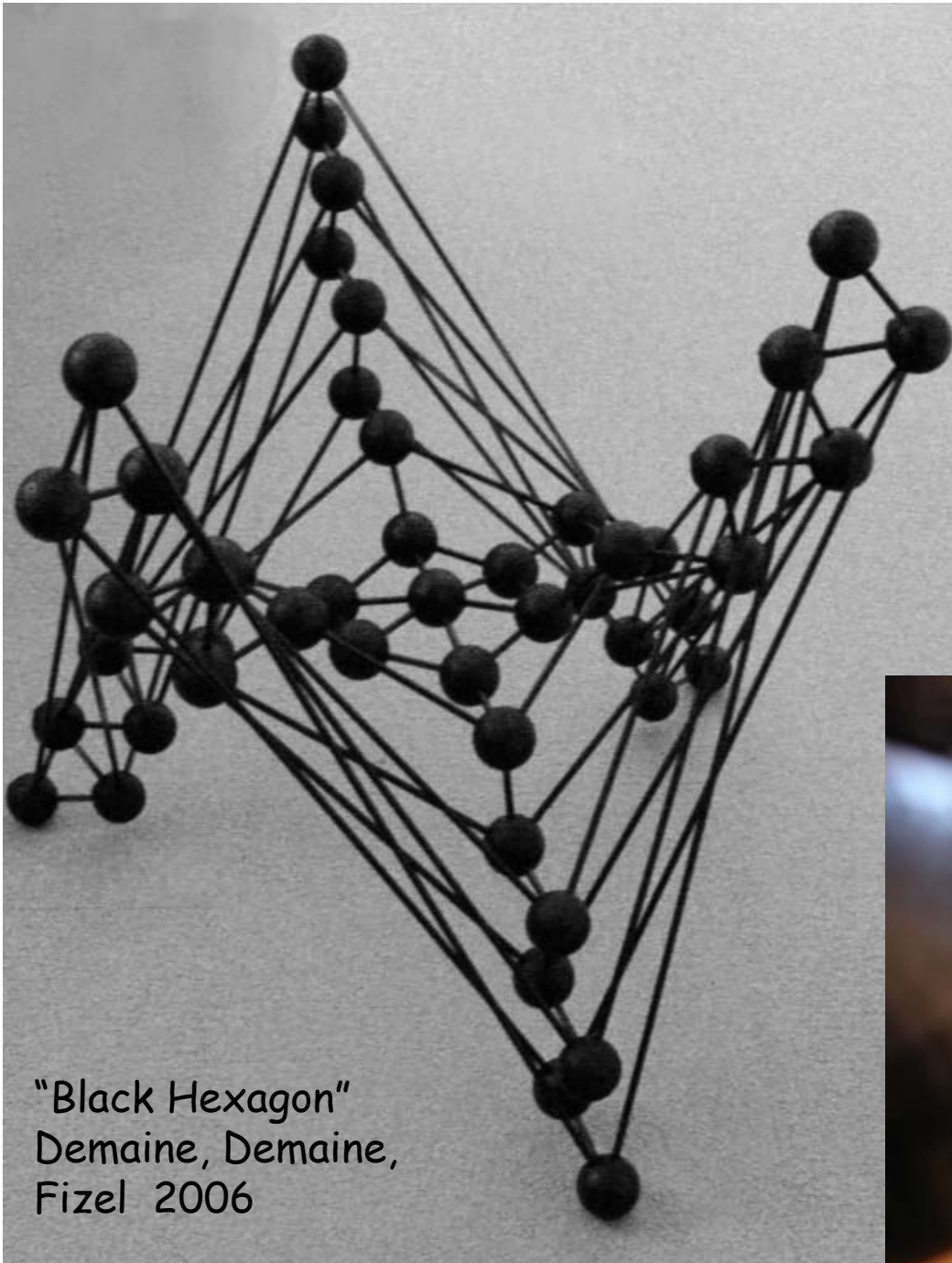

"Black Hexagon"  
Demaine, Demaine,  
Fizel 2006

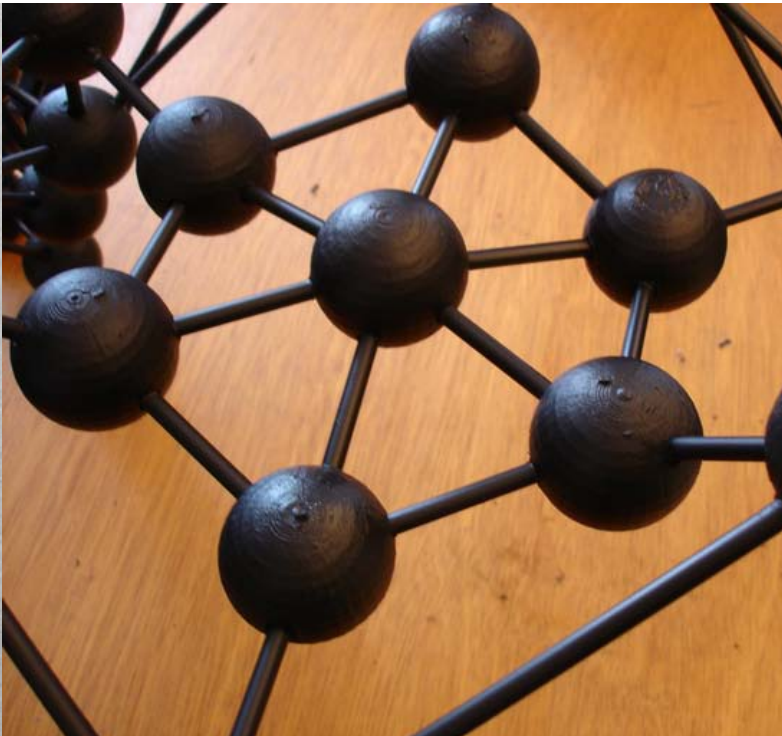

Courtesy of Erik Demaine, Martin Demaine, and Jenna Fizel. Used with permission.

# Hyparhedra: Platonic Solids

[Demaine, Demaine, Lubiw 1999]

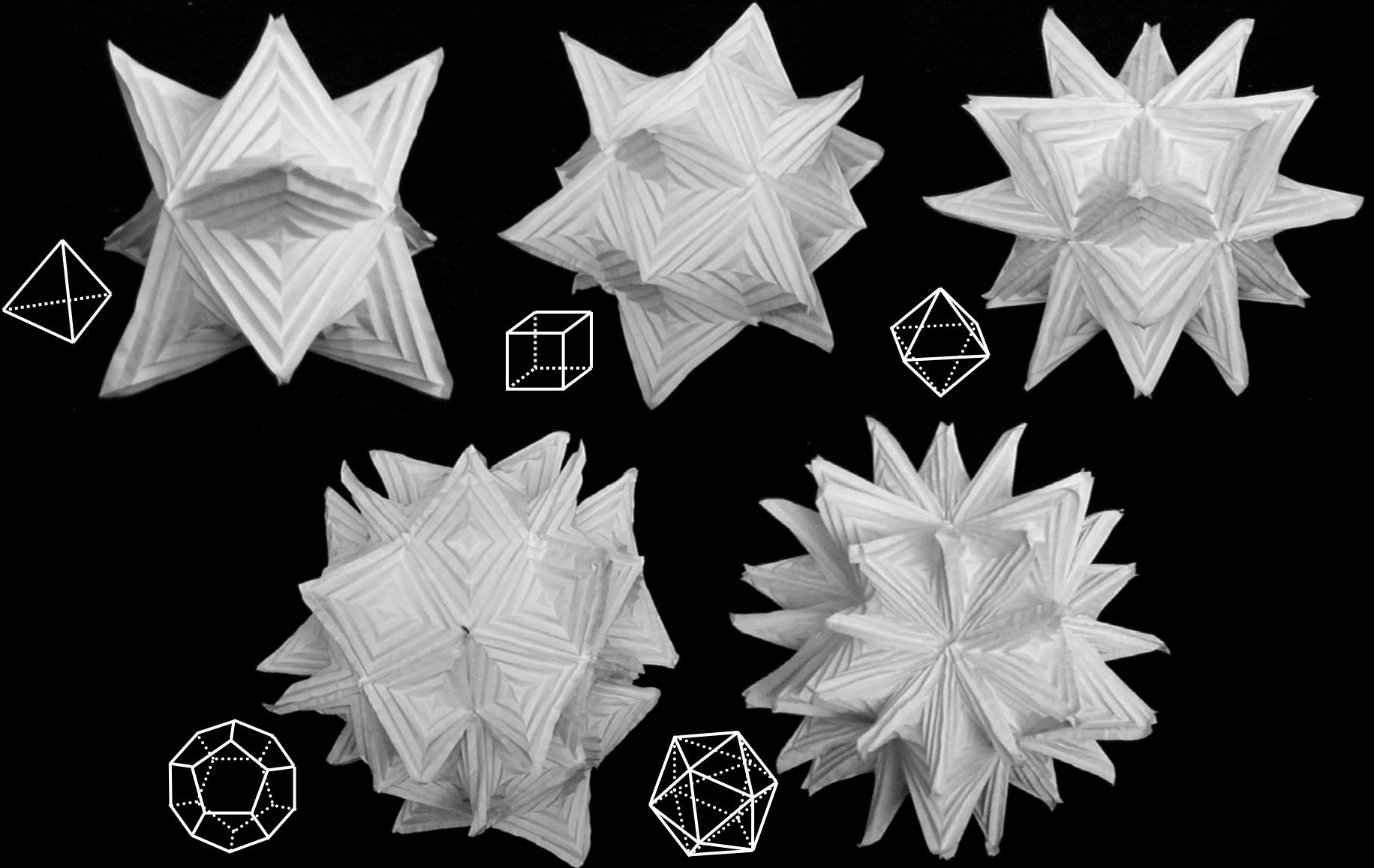

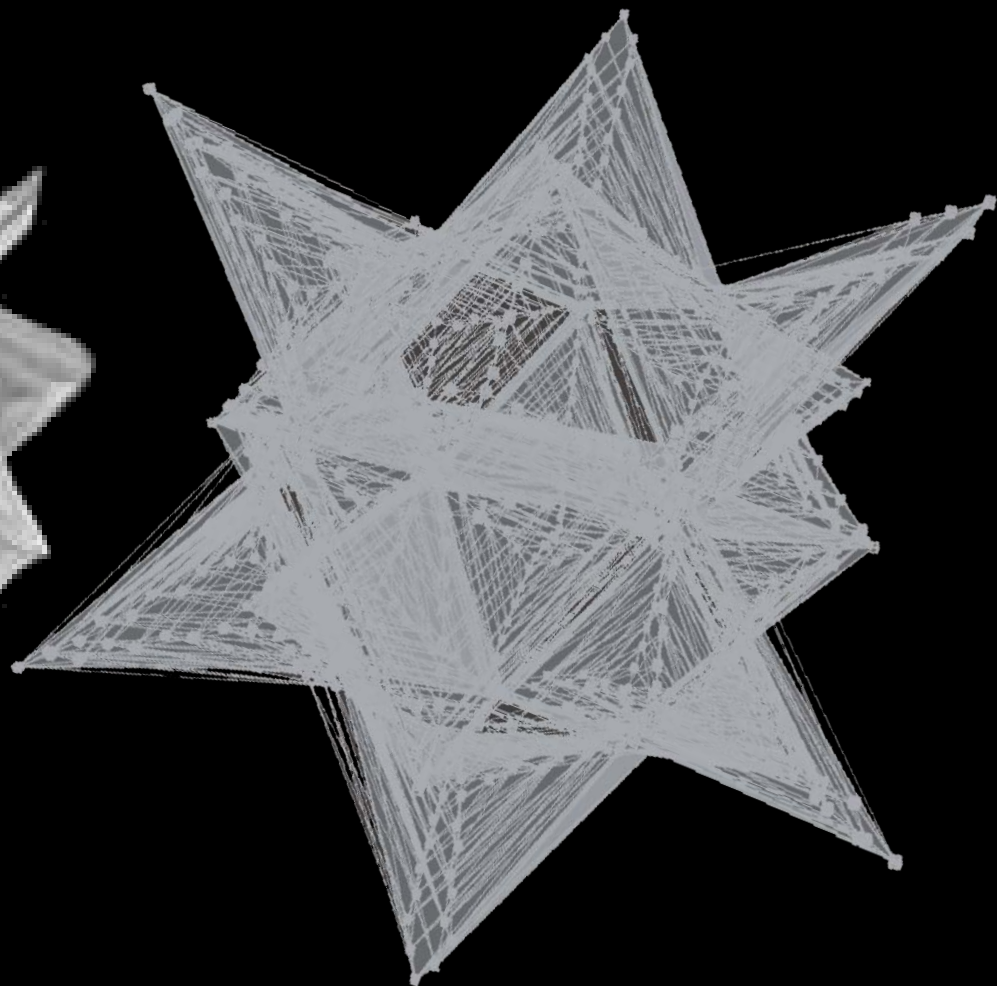

Courtesy of Erik Demaine, Martin Demaine, Jenna Fizel, and John Ochsendorf. Used with permission.

**Virtual Origami**  
Demaine, Demaine, Fizel, Ochsendorf 2006



"Computational Origami"  
Erik & Martin Demaine  
MoMA, 2008-

Elephant hide paper  
~9"x15"x7"



# Peel Gallery, Houston

Nov. 2009

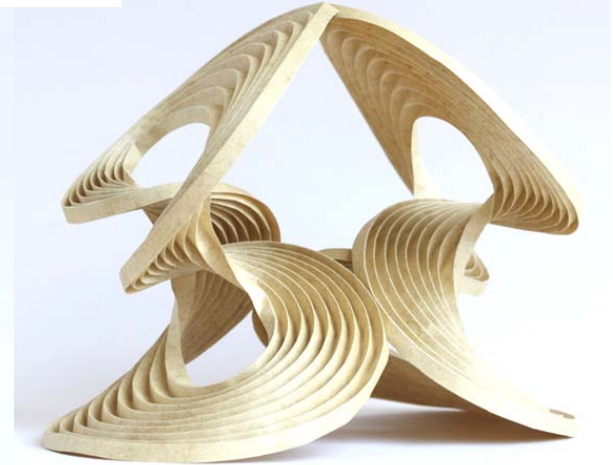

Demaine & Demaine 2009

Courtesy of Erik Demaine and Martin Demaine. Used with permission.  
See also <http://erikdemaine.org/curved/Limit/>.



**"Natural Cycles"**  
Erik & Martin Demaine

JMM Exhibition of  
Mathematical Art,  
San Francisco, 2010



Courtesy of Erik Demaine and Martin Demaine. Used with permission.  
See also <http://erikdemaine.org/curved/NaturalCycles/>.

# Waves in Glass

Erik Demaine  
Martin Demaine



communication between glass & paper

Courtesy of Erik Demaine and Martin Demaine. Used with permission.  
See also <http://erikdemaine.org/curved/BlindGlass/>.

Demaine & Demaine 2010

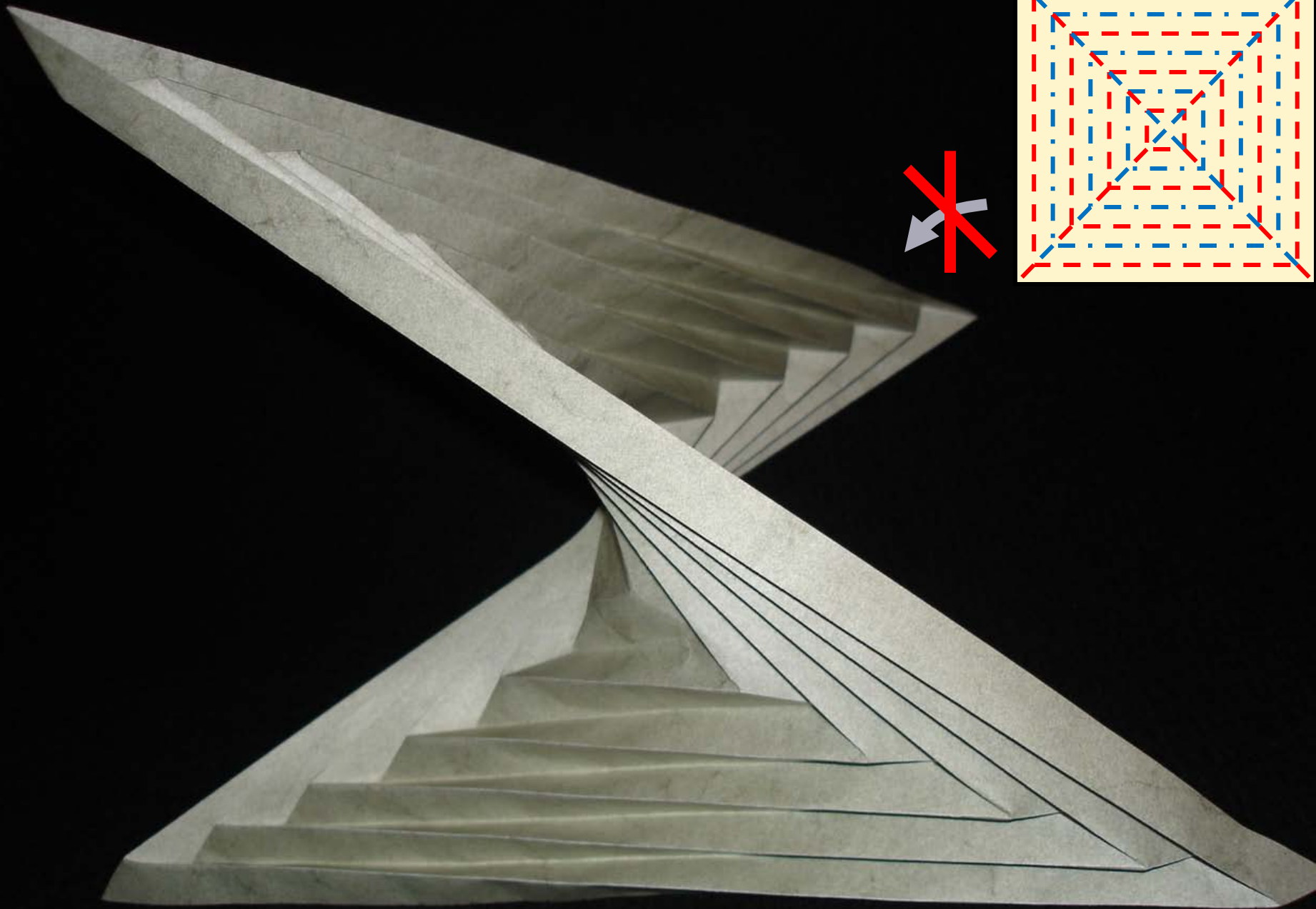

Courtesy of Jenna Fizel. Used with permission.

[Demaine, Demaine, Hart, Price, Tachi 2009/2010]

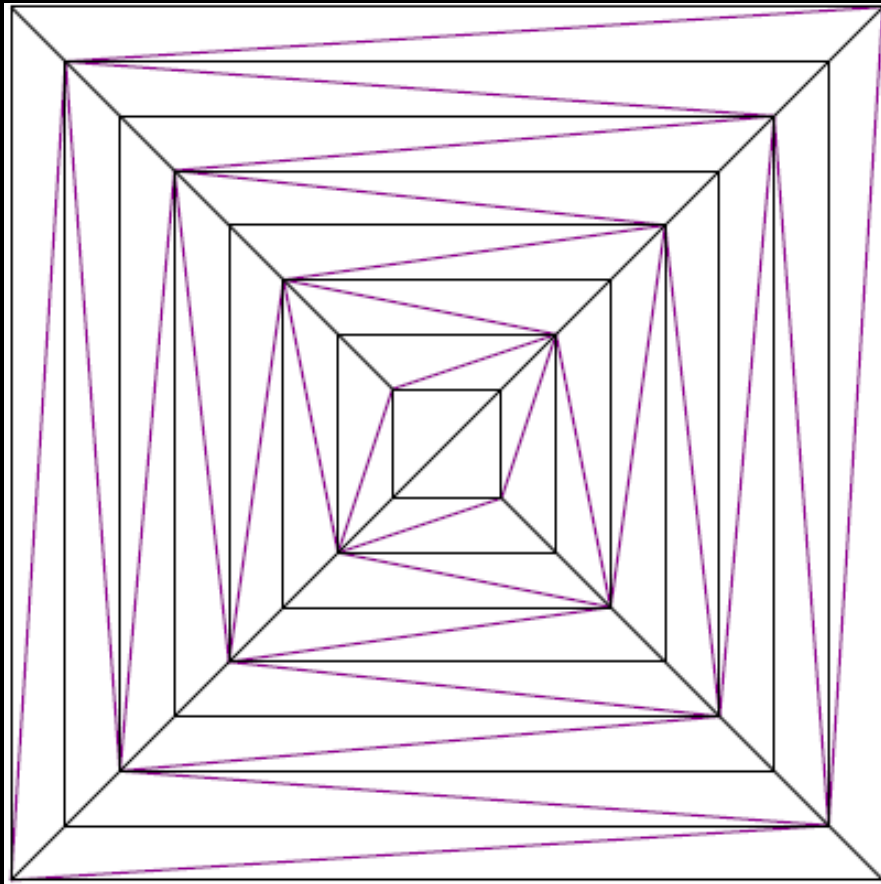

$\theta = 30^\circ$   
 $n = 16$

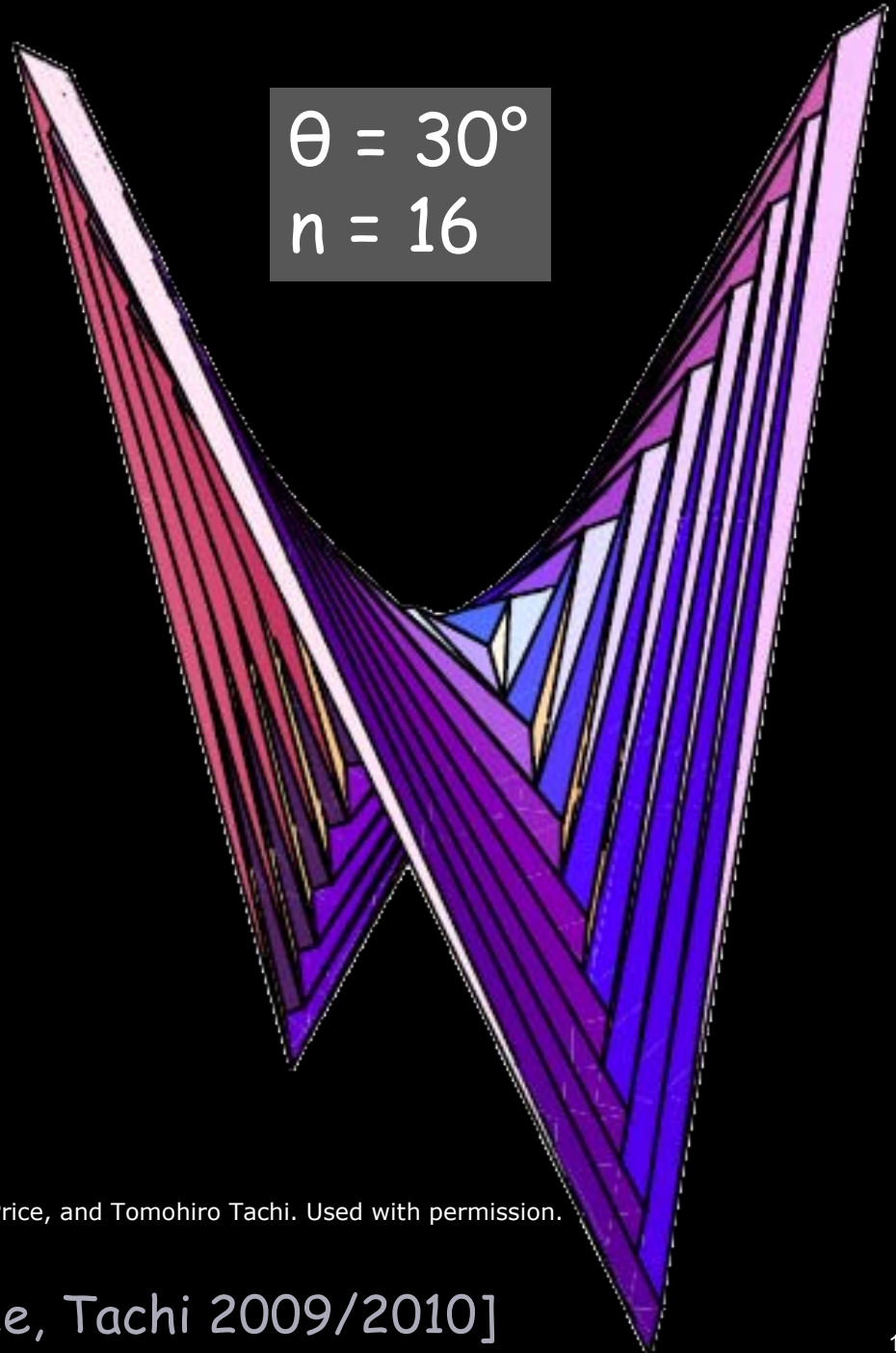

Courtesy of Erik D. Demaine, Martin L. Demaine, Vi Hart, Gregory N. Price, and Tomohiro Tachi. Used with permission.

[Demaine, Demaine, Hart, Price, Tachi 2009/2010]



[Demaine,  
Demaine,  
Hart, Price,  
Tachi  
2009/2010]

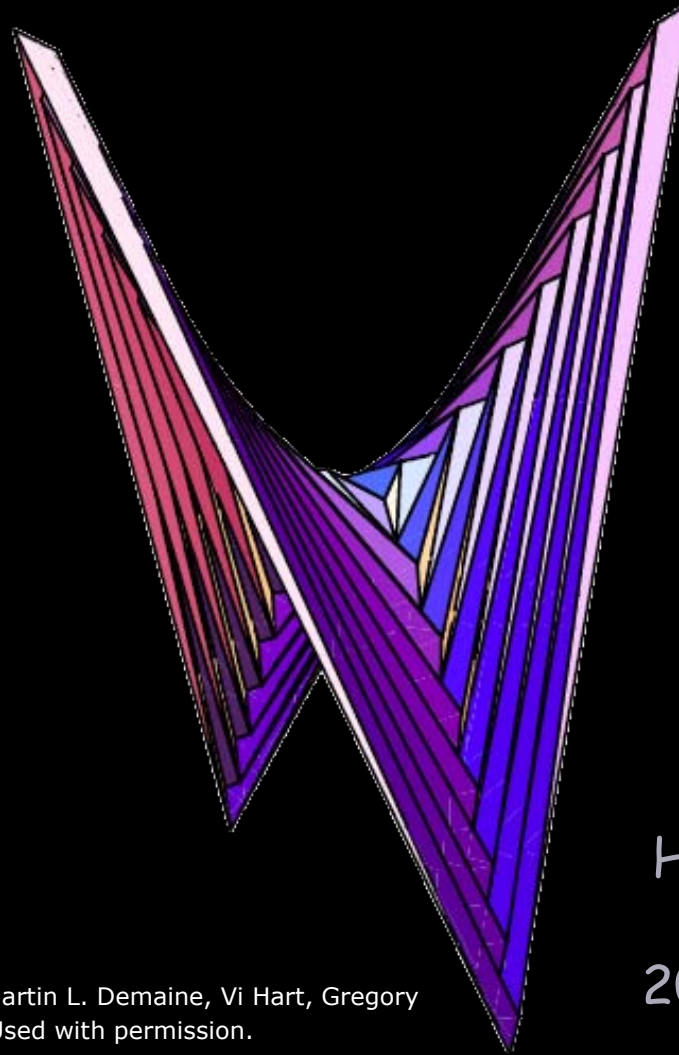
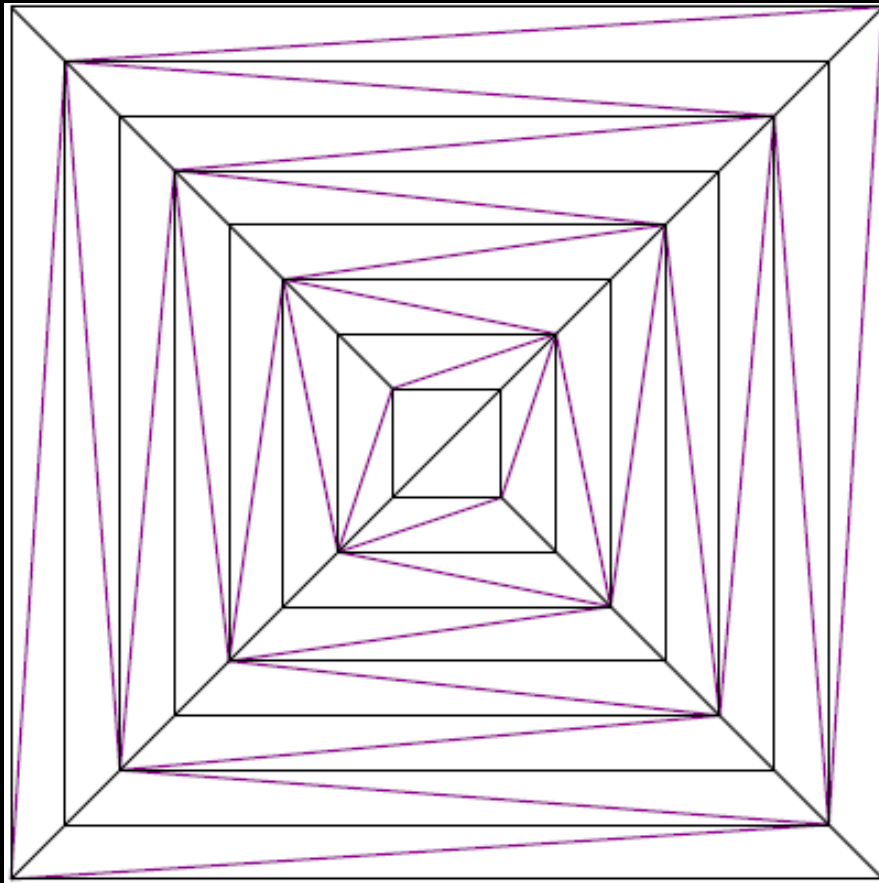

[Demaine,  
Demaine,  
Hart, Price,  
Tachi  
2009/2010]

Courtesy of Erik D. Demaine, Martin L. Demaine, Vi Hart, Gregory N. Price, and Tomohiro Tachi. Used with permission.

digits of precision	16	32	64	128	256	512	1024	2048
$n$ for $\theta = 1^\circ$ alt.	3	6	12	24	43	79	$\geq 100$	
$n$ for $\theta = 45^\circ$ alt.	3	5	10	18	32	58	$\geq 100$	
$n$ for $\theta = 76^\circ$ alt.	2	5	9	16	29	53	95	$\geq 100$



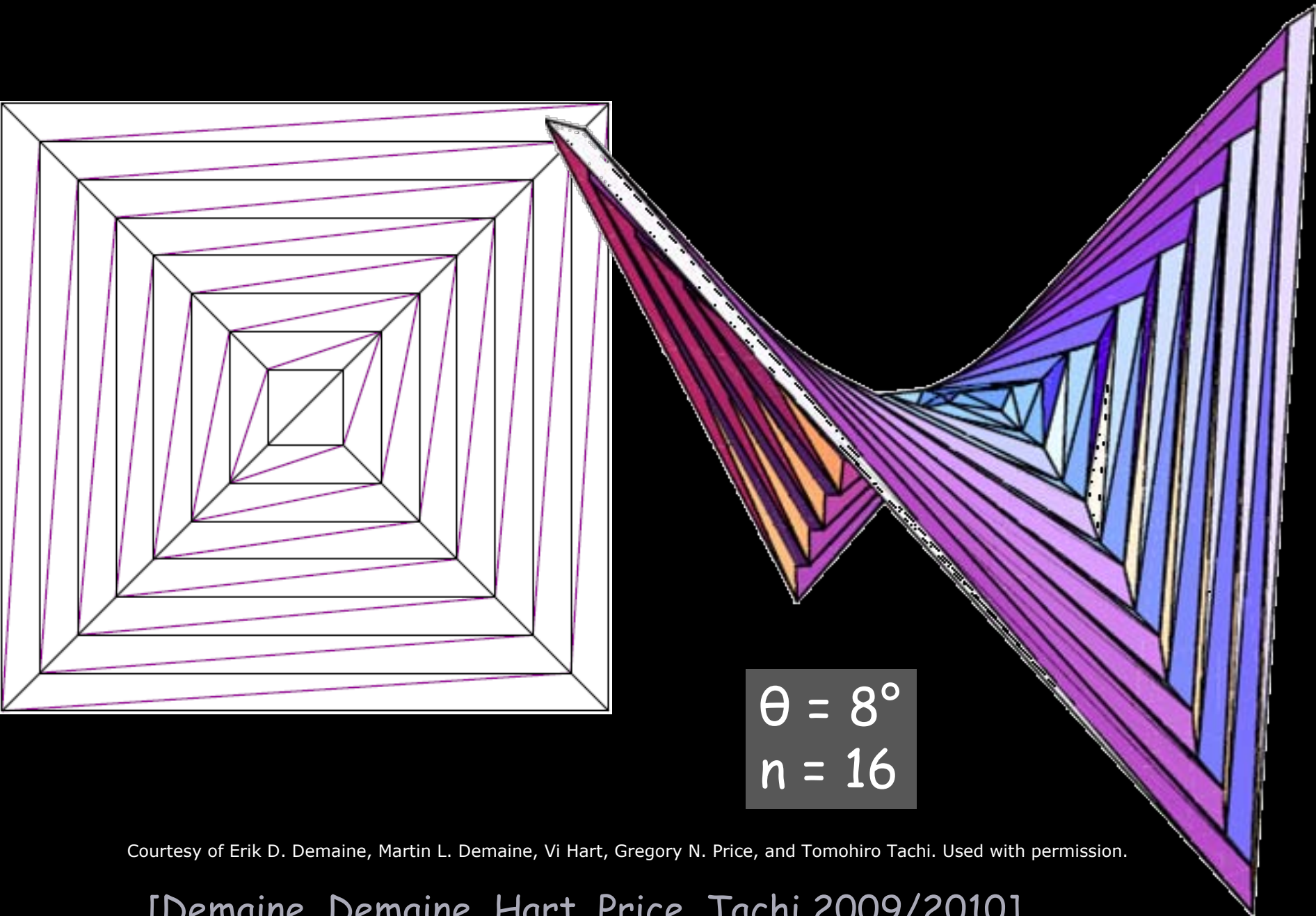

Courtesy of Erik D. Demaine, Martin L. Demaine, Vi Hart, Gregory N. Price, and Tomohiro Tachi. Used with permission.

[Demaine, Demaine, Hart, Price, Tachi 2009/2010]

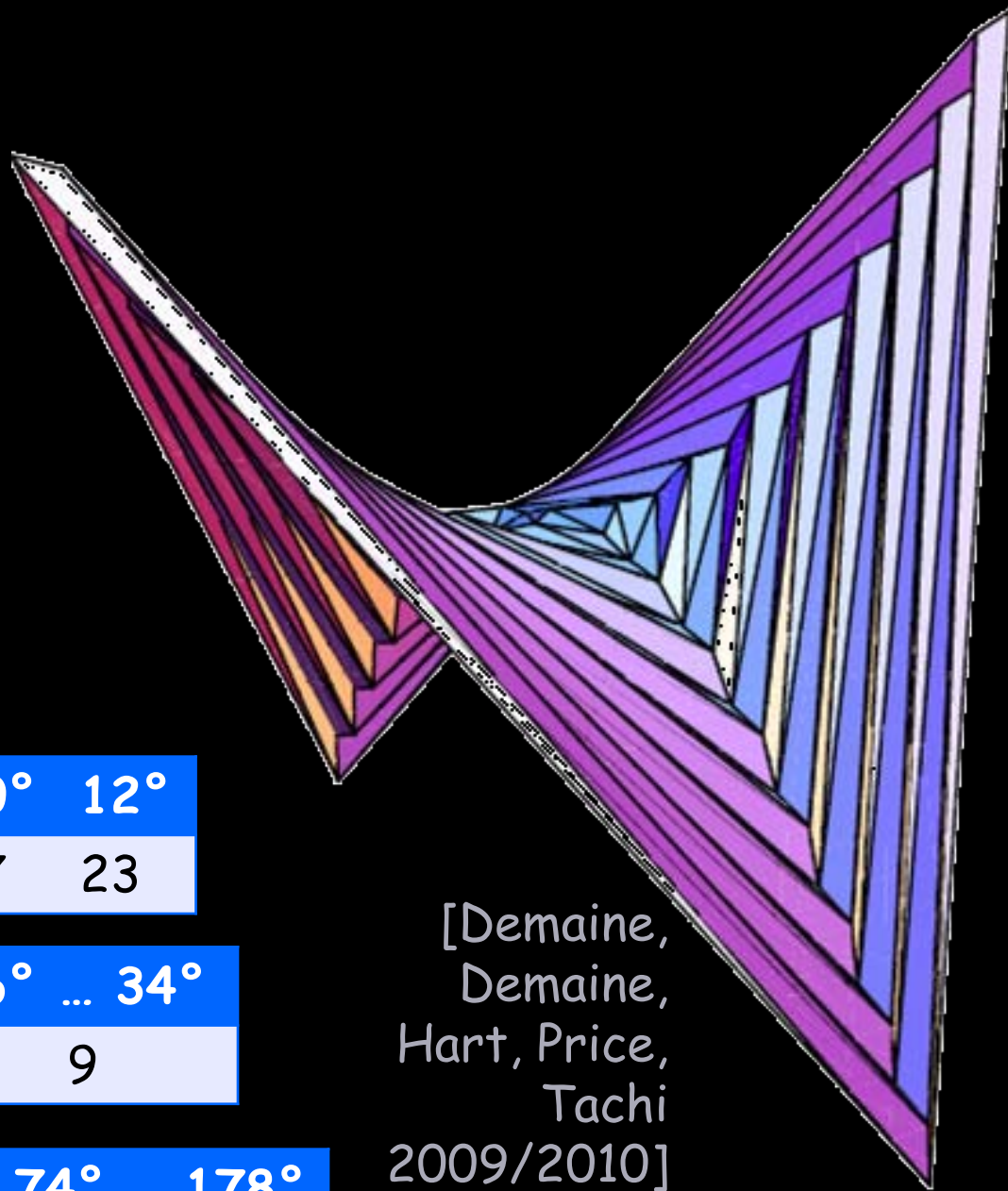
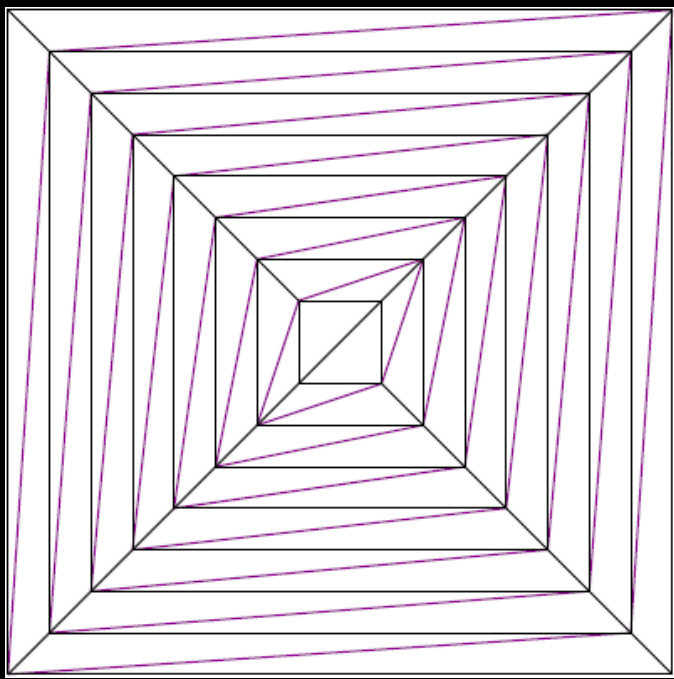

Courtesy of Erik D. Demaine, Martin L. Demaine, Vi Hart, Gregory N. Price, and Tomohiro Tachi. Used with permission.

$\theta =$	$2^\circ$	$4^\circ$	$6^\circ$	$8^\circ$	$10^\circ$	$12^\circ$
$n \leq$	133	67	45	33	27	23

$\theta =$	$18^\circ$	$20^\circ$	$22^\circ$	$24^\circ$	$26^\circ$	...	$34^\circ$
$n \leq$	15	13	13	11			9

$\theta =$	$36^\circ$	...	$46^\circ$	$48^\circ$	...	$72^\circ$	$74^\circ$	...	$178^\circ$
$n \leq$	7	...	7	5	...	5	3	...	3

[Demaine,  
Demaine,  
Hart, Price,  
Tachi  
2009/2010]

Courtesy of Erik D. Demaine, Martin L. Demaine, Vi Hart, Gregory N. Price, and Tomohiro Tachi. Used with permission.

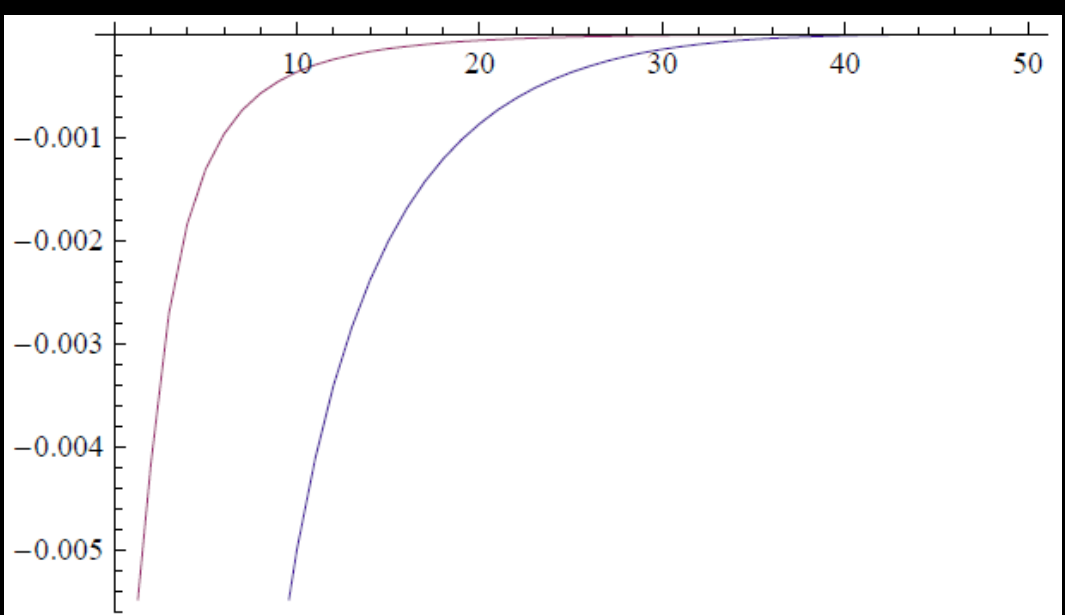
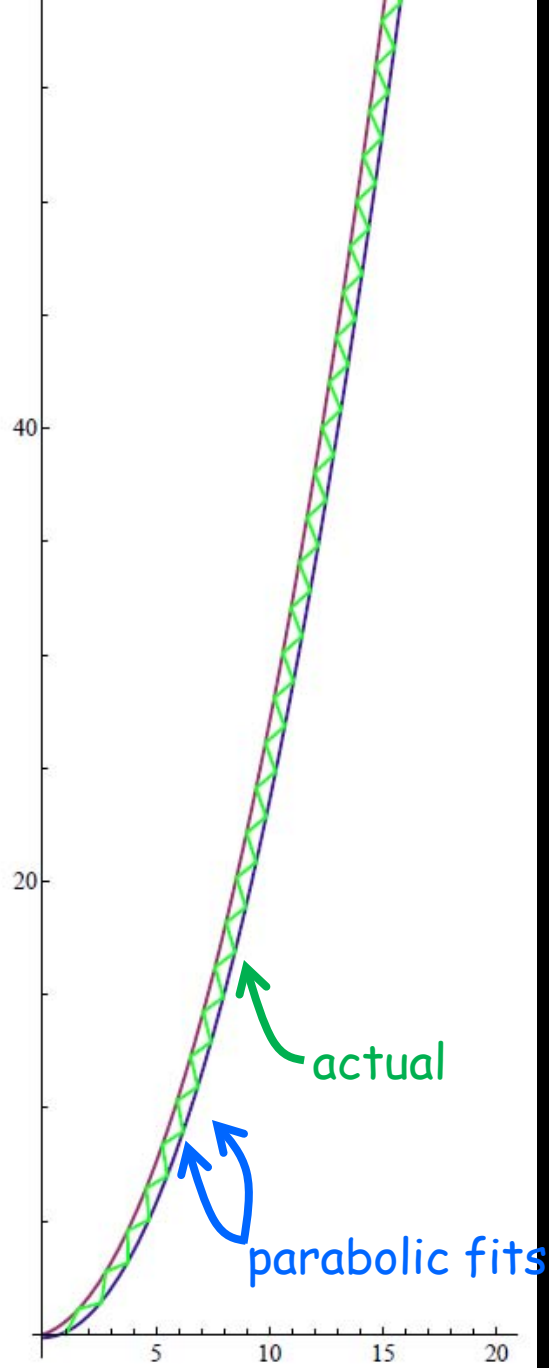

(b) Absolute difference: fit minus actual.

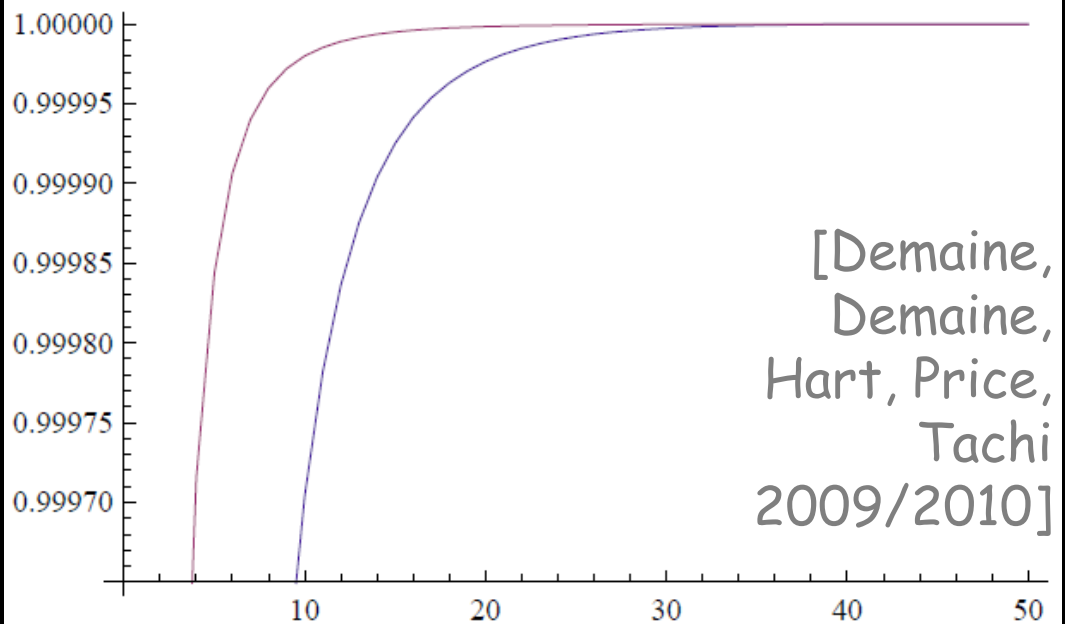

(c) Relative difference: fit over actual.

[Demaine,  
Demaine,  
Hart, Price,  
Tachi  
2009/2010]

Image removed due to copyright restrictions.

Refer to: [http://en.wikipedia.org/wiki/File:Minimal\\_surface\\_curvature\\_planes-en.svg](http://en.wikipedia.org/wiki/File:Minimal_surface_curvature_planes-en.svg)

Image removed due to copyright restrictions. Refer to: [http://en.wikipedia.org/wiki/File:Ruled\\_hyperboloid.jpg](http://en.wikipedia.org/wiki/File:Ruled_hyperboloid.jpg)  
and <http://en.wikipedia.org/wiki/File:Helixtgtdev.png>.

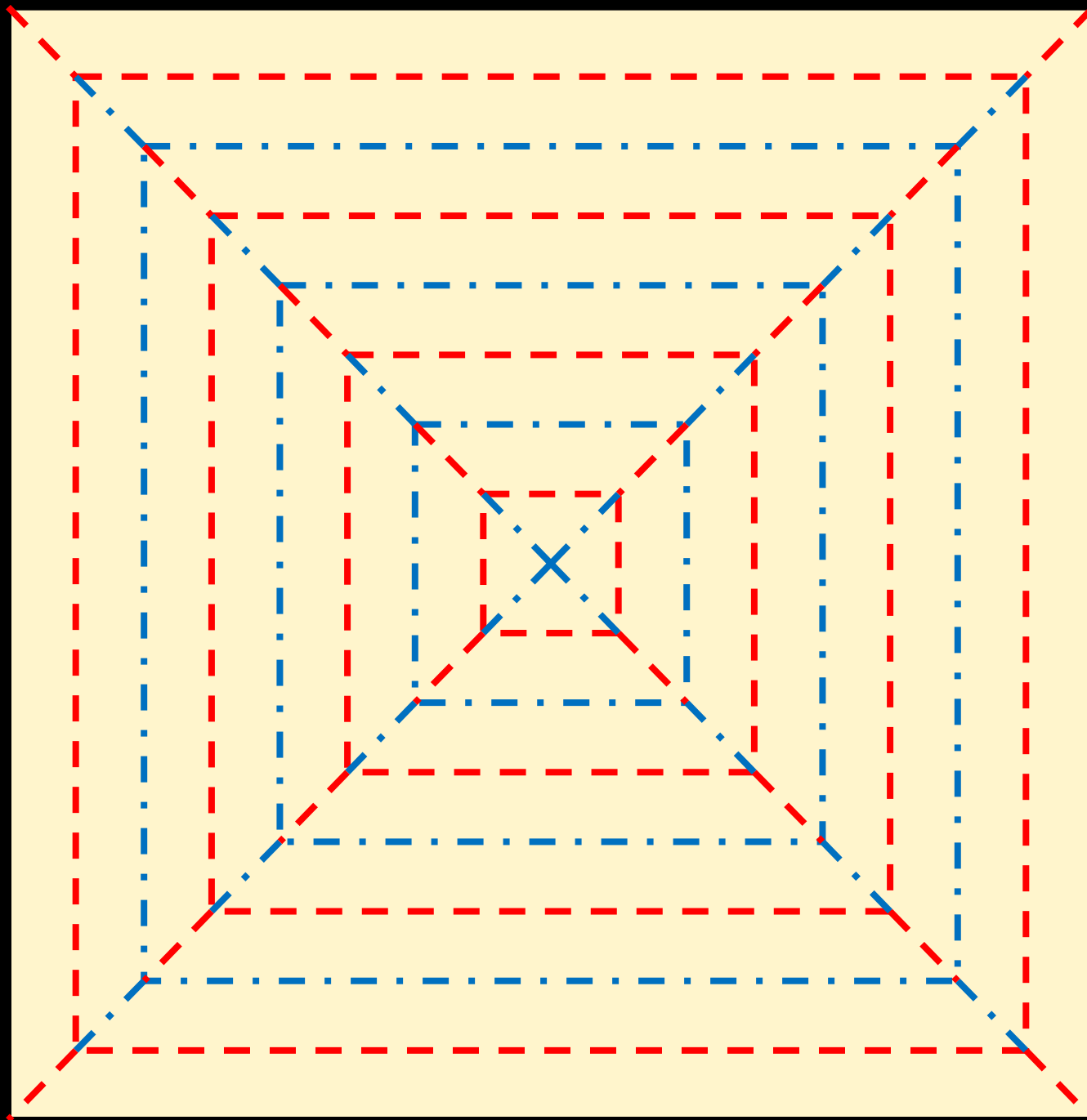

[Demaine,  
Demaine,  
Hart, Price,  
Tachi  
2009/2010]

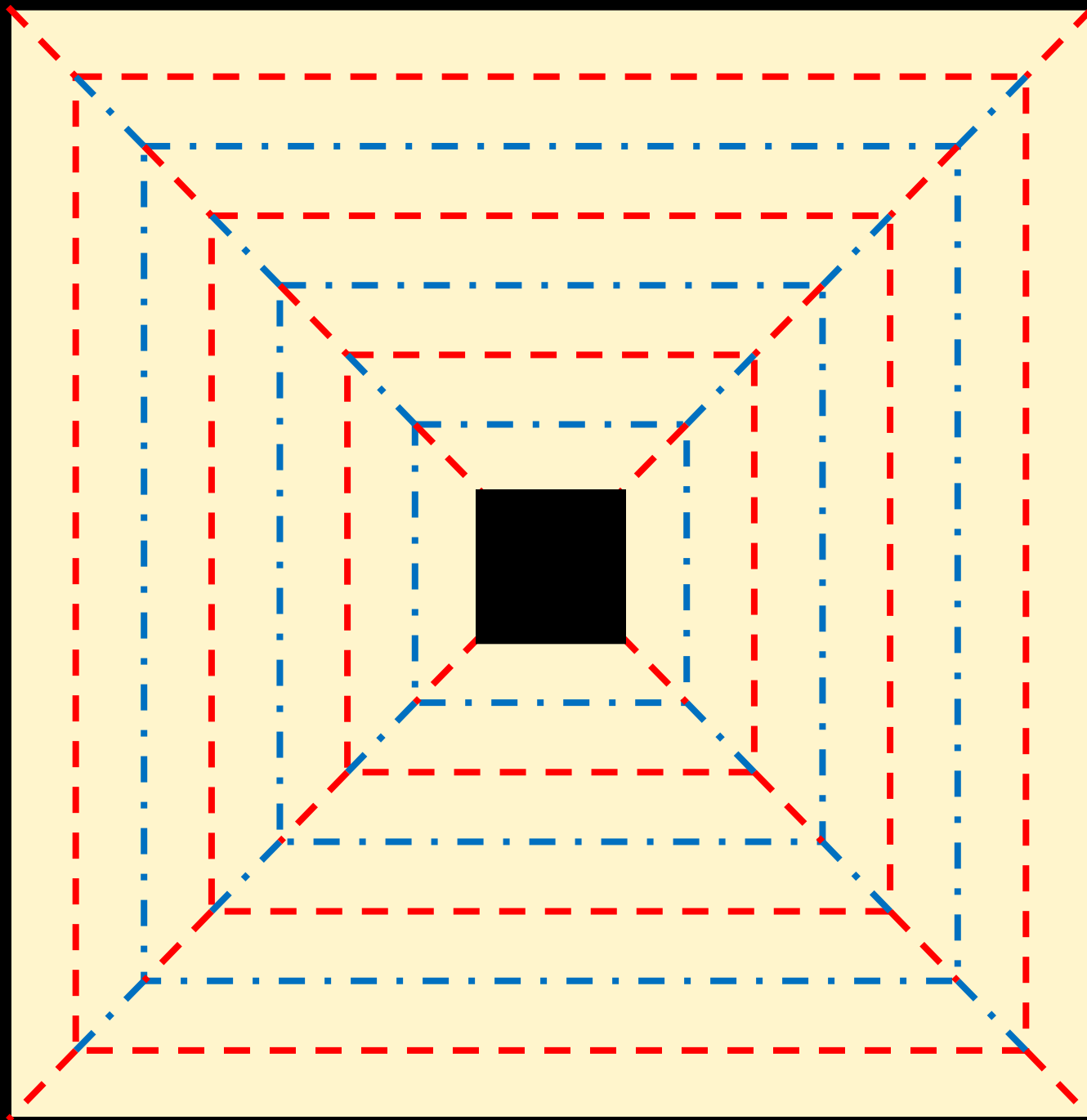

[Demaine,  
Demaine,  
Hart, Price,  
Tachi  
2009/2010]

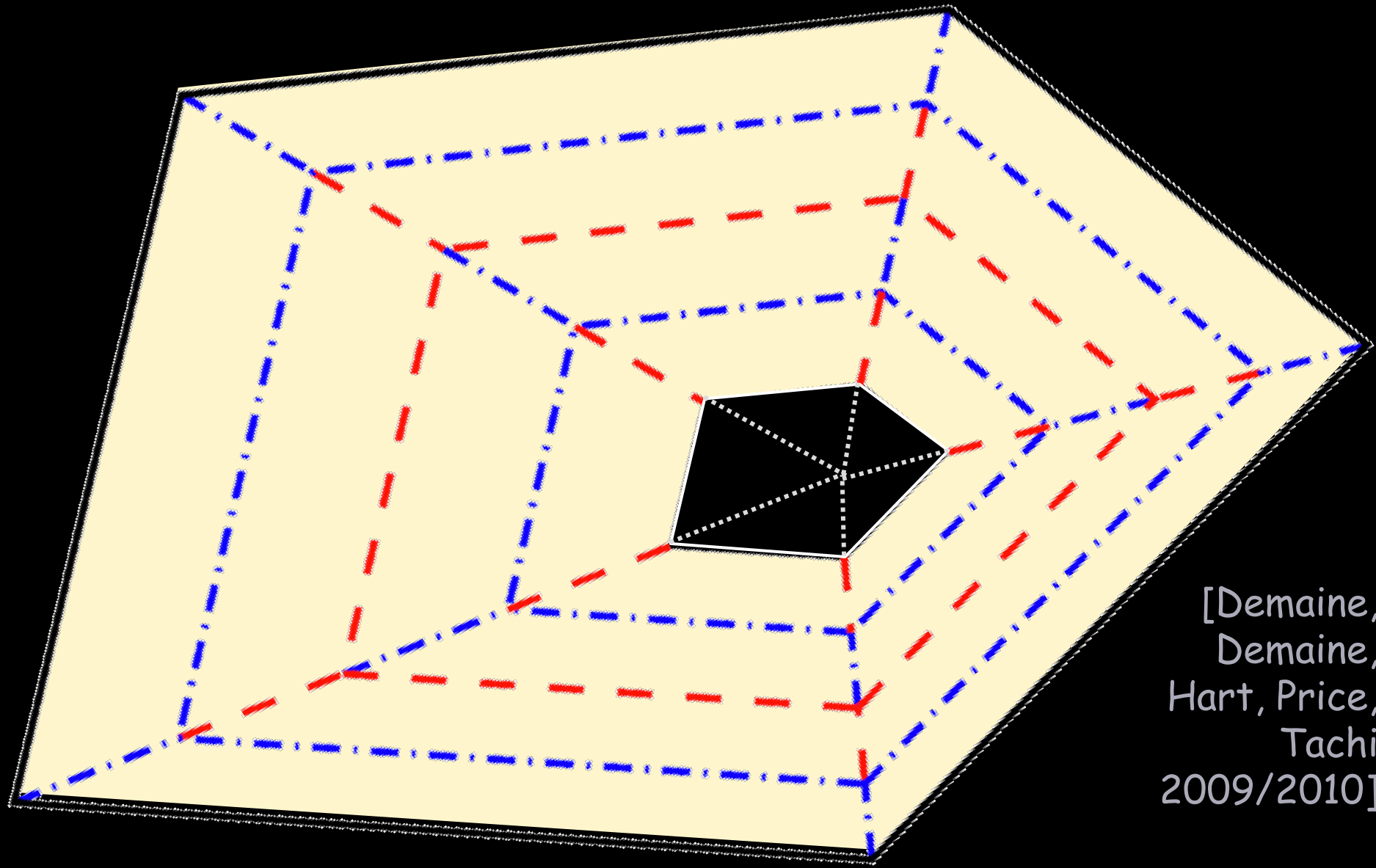

[Demaine,  
Demaine,  
Hart, Price,  
Tachi  
2009/2010]

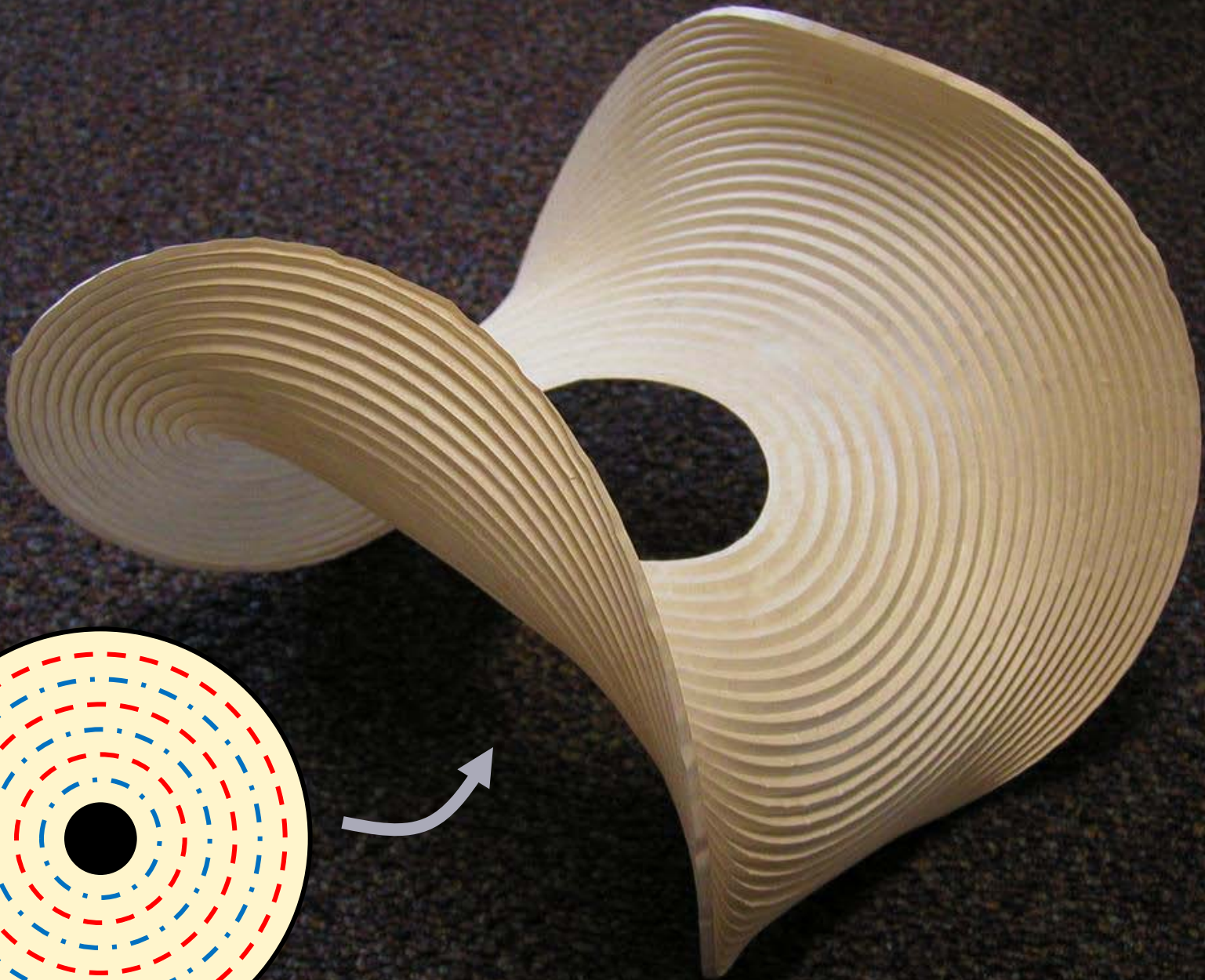
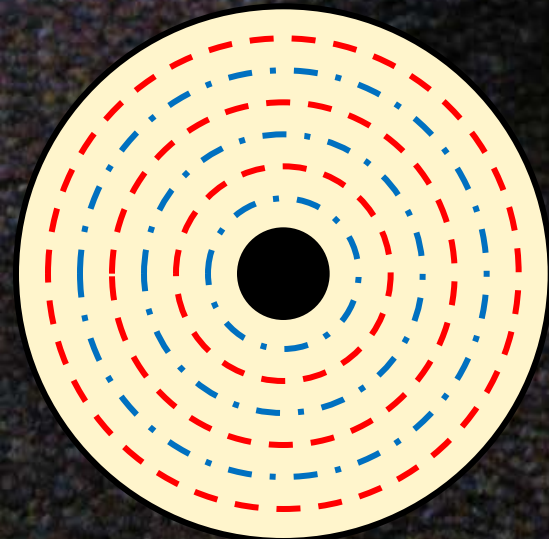



Photo courtesy of [gin\\_able](#) on Flickr. Used with permission. Under CC-BY-NC.



Photo courtesy of [themacinator](#) on Flickr. Used with permission. Under CC-BY.



[Albers at Bauhaus, 1927-1928]

# Huffman Family (May 2010)



Linda Marilyn Elise

# Tessellations

**circles**

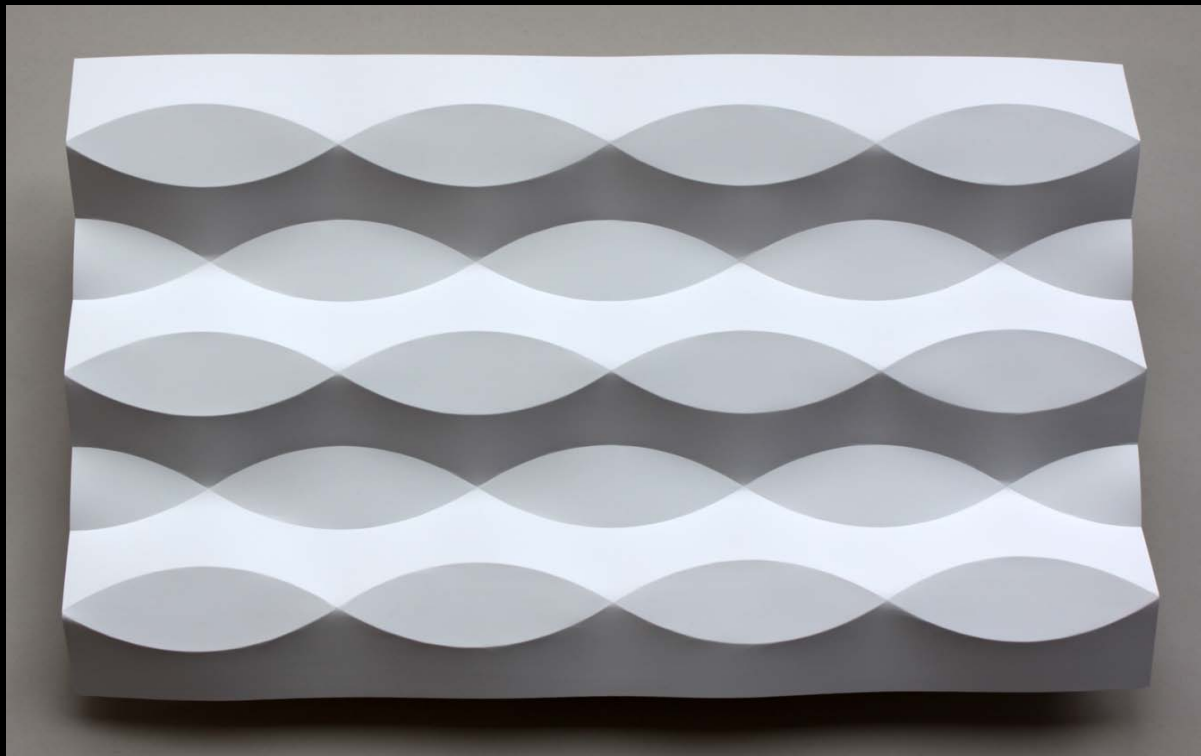
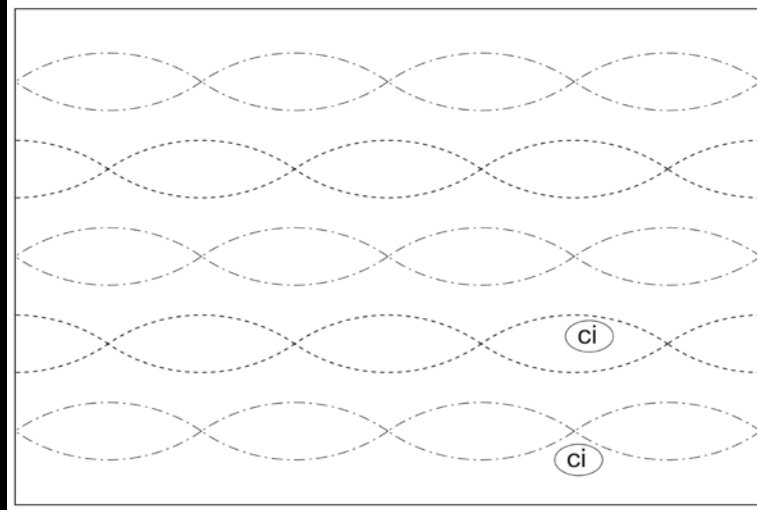

Courtesy of Erik D. Demaine, Martin L. Demaine, and Duks Koschitz. Used with permission.

design by David Huffman; recreated folding by Demaine, Demaine, Koschitz 2010

# Tessellations

## "Arches"

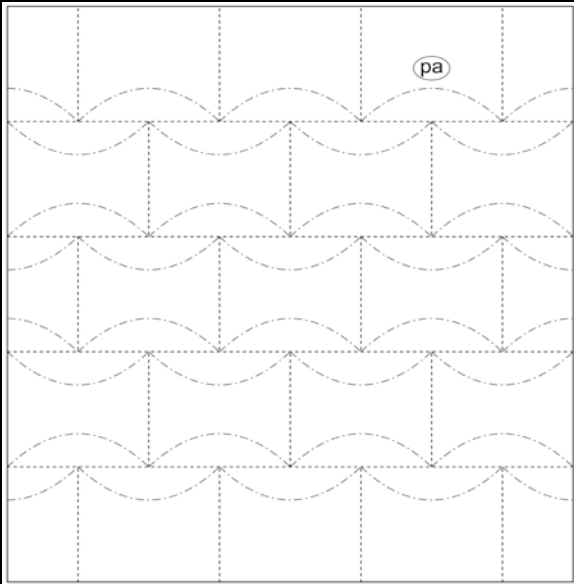

parabolas  
& lines

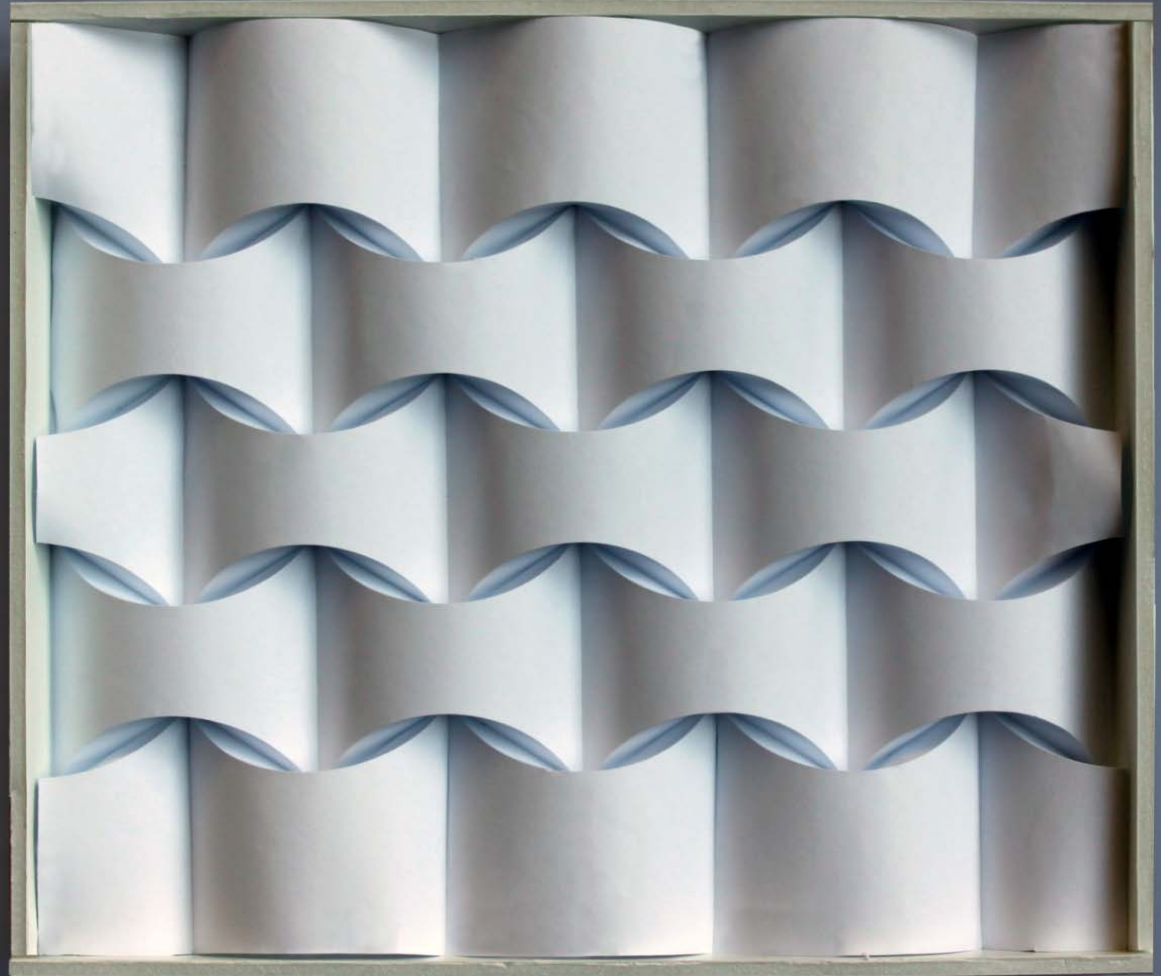

Courtesy of Erik D. Demaine, Martin L. Demaine, and Duks Koschitz. Used with permission.

design by David Huffman; recreated folding by Demaine, Demaine, Koschitz 2010

"Cone reflected 7 times"

circles & nonconics

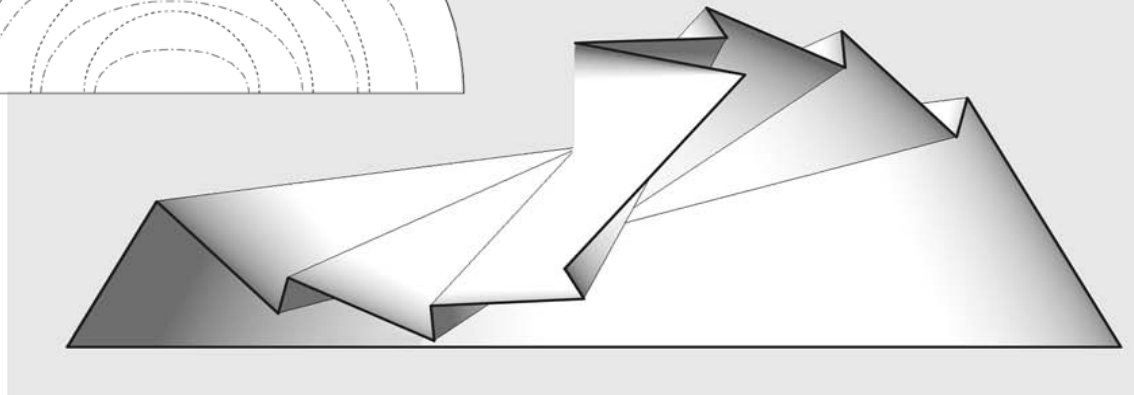
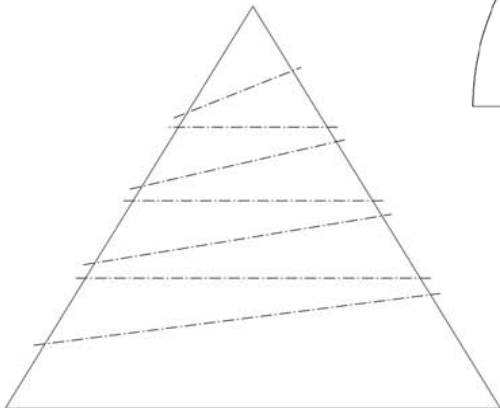
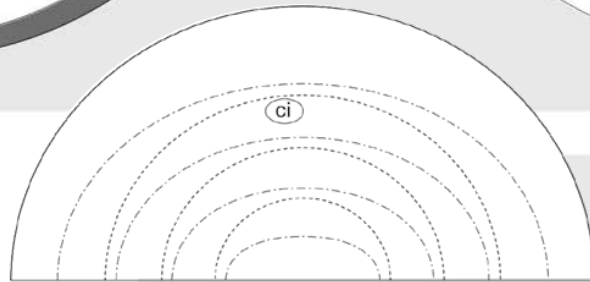
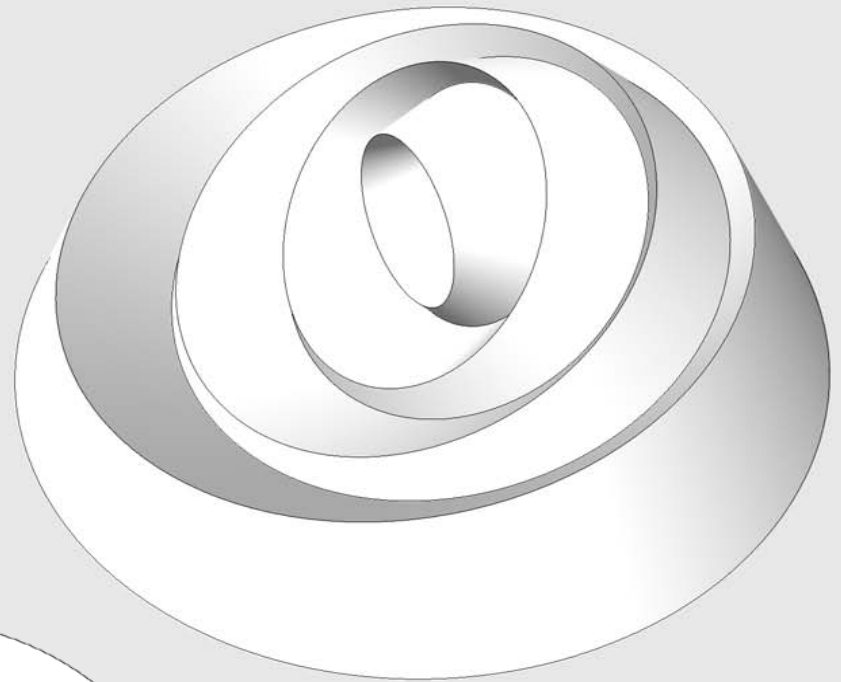
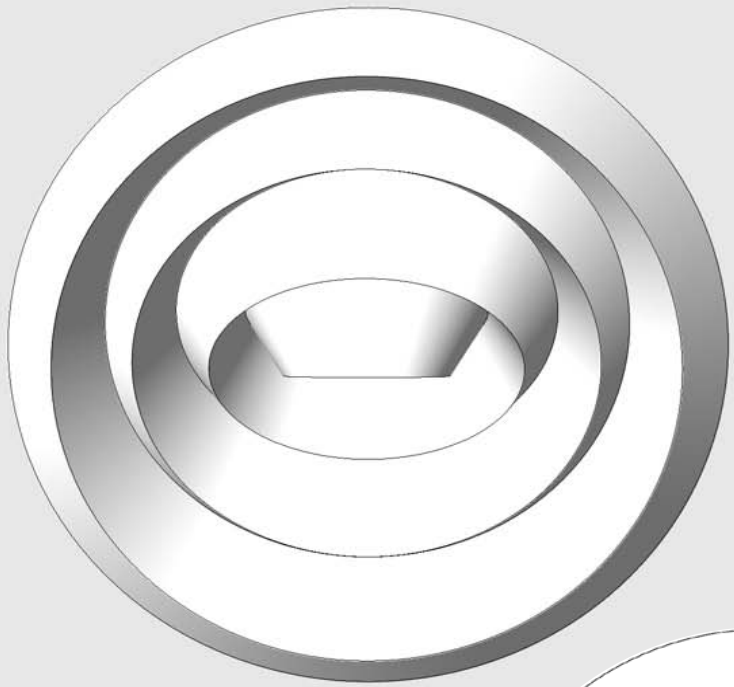

Courtesy of Erik D. Demaine, Martin L. Demaine, and Duks Koschitz. Used with permission.

design by David Huffman; virtual model by Demaine, Demaine, Koschitz 2010

"Hexagonal column with cusps"  
(two variations)

circles  
& lines

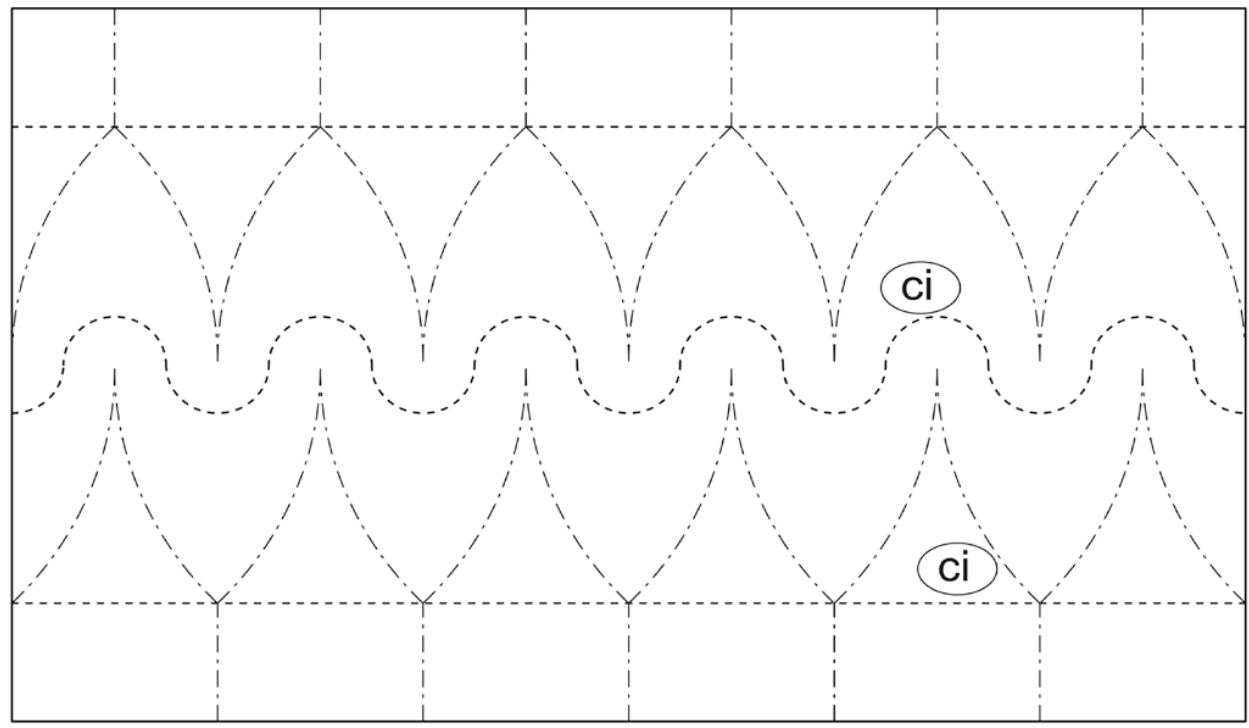
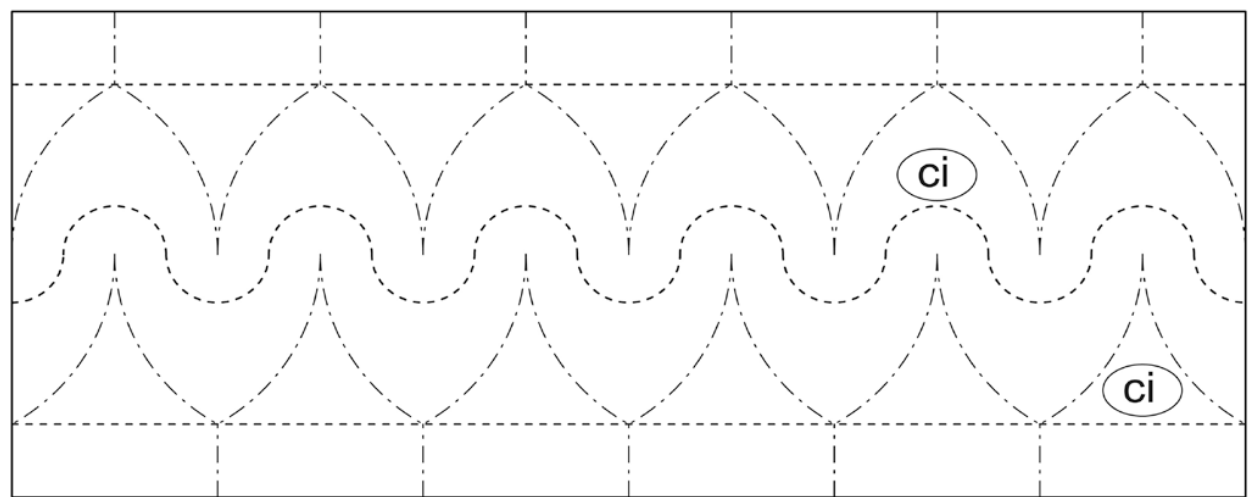

Courtesy of Erik D. Demaine, Martin L. Demaine, and Duks Koschitz. Used with permission.



# "Hexagonal column with cusps"

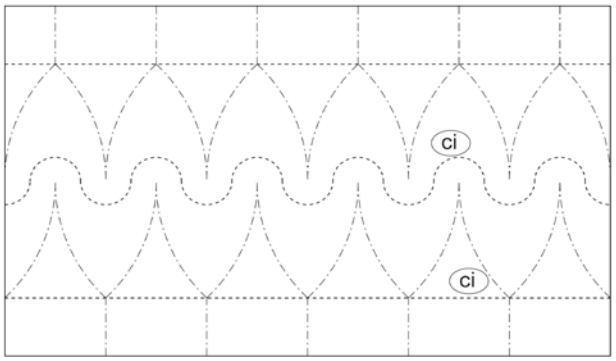
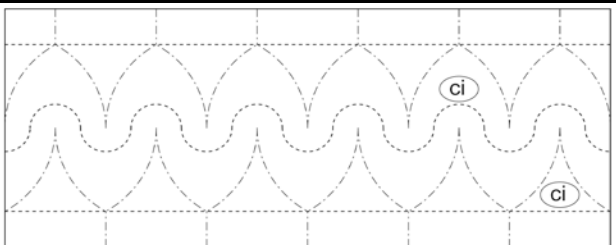

**circles  
& lines**



Courtesy of Erik D. Demaine, Martin L. Demaine, and Duks Koschitz. Used with permission.

"4-lobed  
cloverleaf"

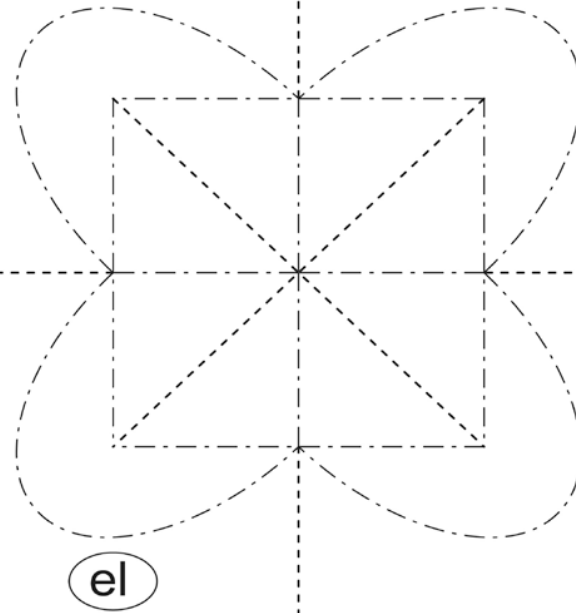

ellipses  
& lines

Courtesy of Erik D. Demaine, Martin L. Demaine, and Duks Koschitz. Used with permission.

design by David Huffman; recreated folding by Demaine, Demaine, Koschitz 2010

"4-lobed  
cloverleaf"

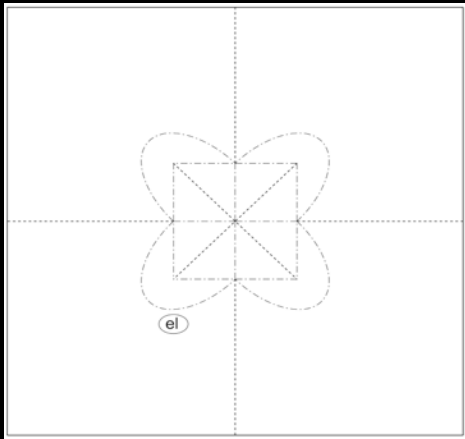

ellipses  
& lines



Courtesy of Erik D. Demaine, Martin L. Demaine, and Duks Koschitz. Used with permission.

design by David Huffman; recreated folding by Demaine, Demaine, Koschitz 2010 <sup>35</sup>

"One column"

parabolas  
& lines

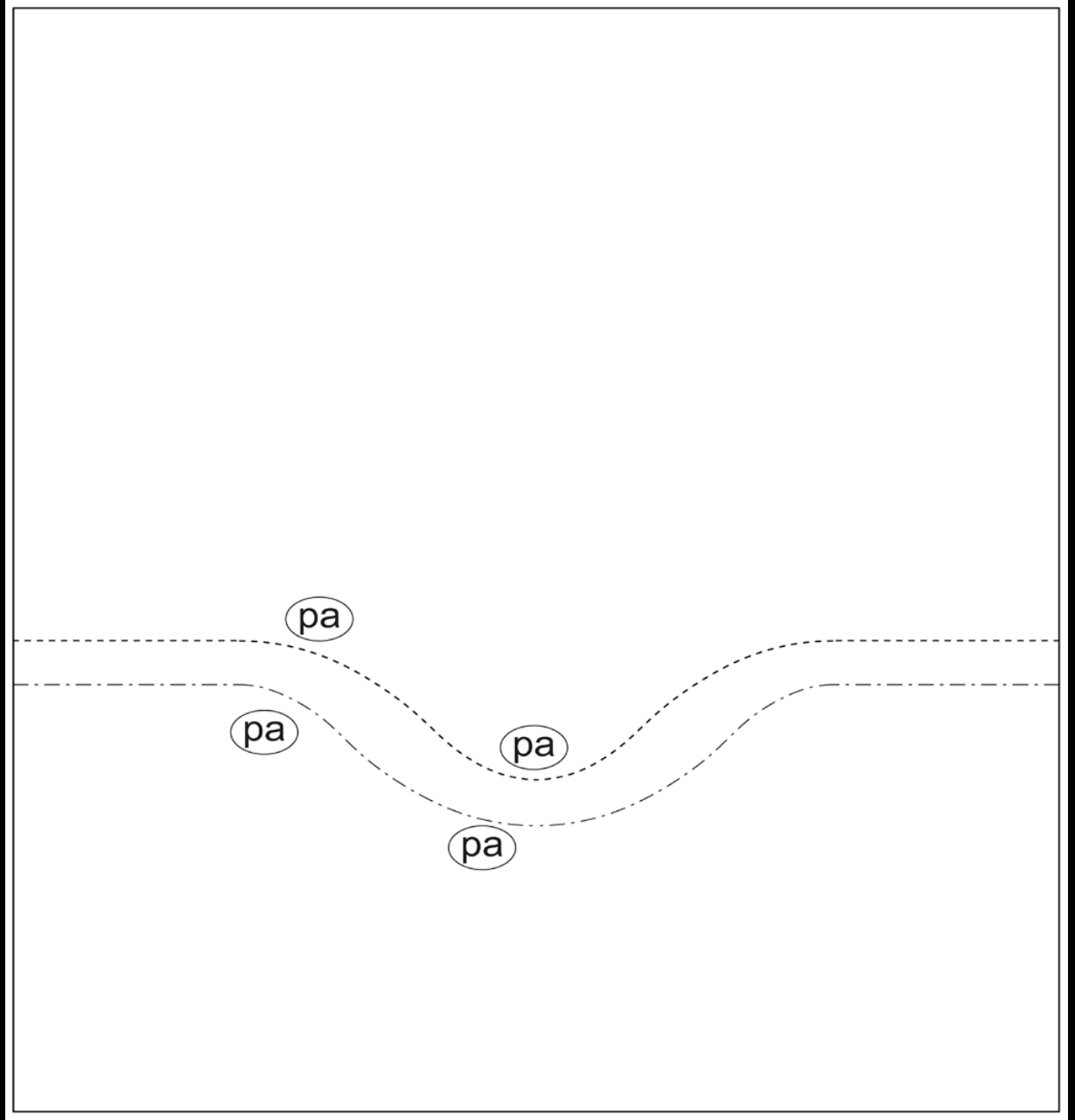

Courtesy of Erik D. Demaine, Martin L. Demaine, and Duks Koschitz. Used with permission.

design by David Huffman; recreated folding by Demaine, Demaine, Koschitz 2010

"One column"

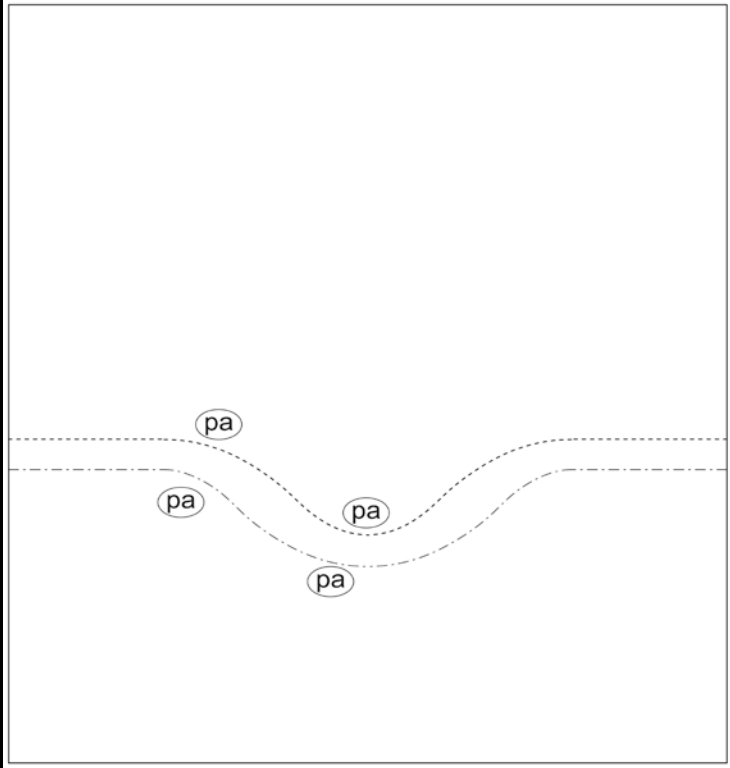

parabolas  
& lines

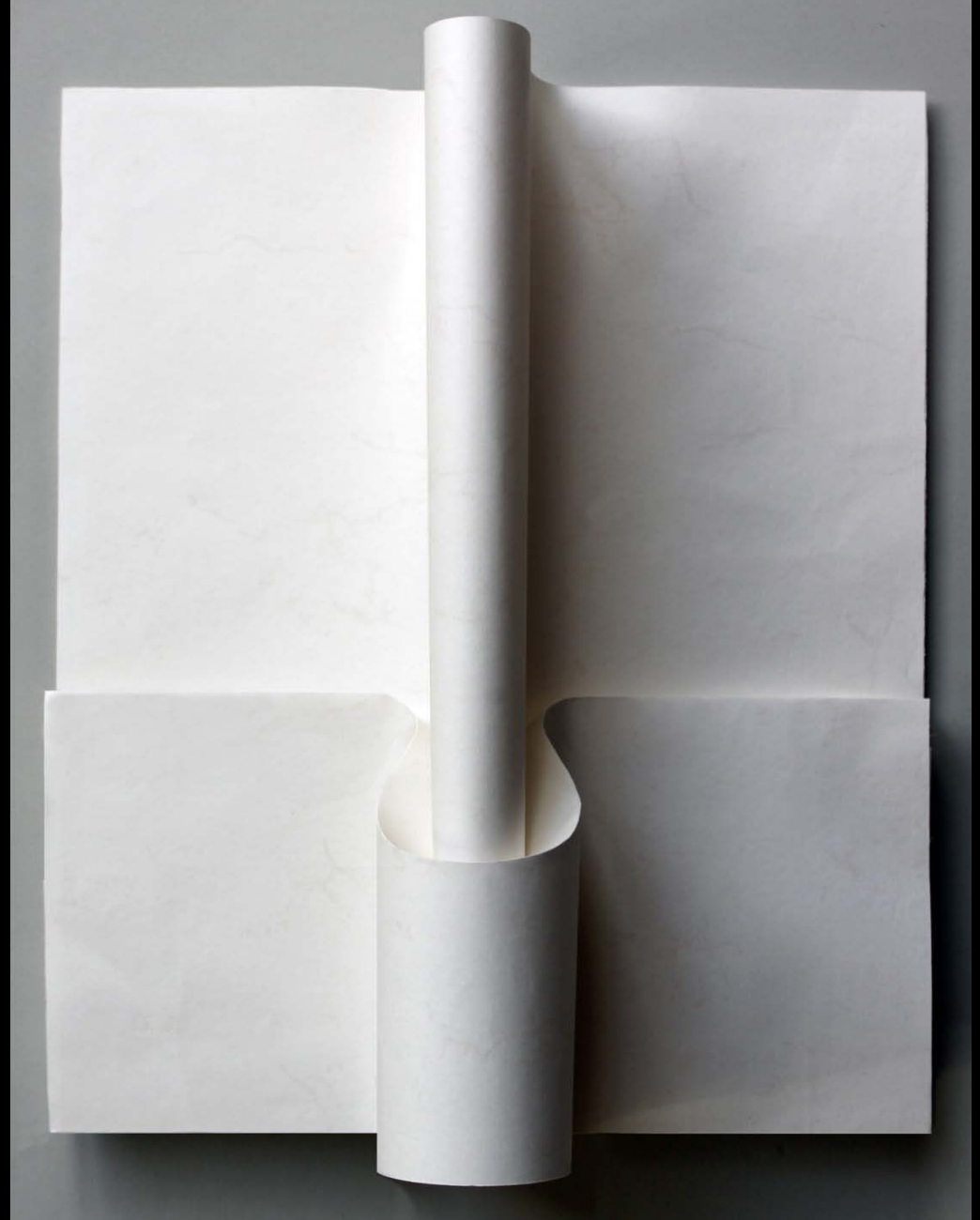

Courtesy of Erik D. Demaine, Martin L. Demaine, and Duks Koschitz. Used with permission.

design by David Huffman; recreated folding by Demaine, Demaine, Koschitz 2010 37

# Huffman Family (May 2010)



Linda Marilyn Elise

MIT OpenCourseWare  
<http://ocw.mit.edu>

6.849 Geometric Folding Algorithms: Linkages, Origami, Polyhedra  
Fall 2012

For information about citing these materials or our Terms of Use, visit: <http://ocw.mit.edu/terms>.